

To: All Toyota Dealer Principals, Service Managers, Parts Managers

Subject: Safety Recall – 90L  
Certain 2007 – 2010 Model Year Camry and Camry Hybrid Vehicles  
Potential Floor Mat Interference with Accelerator Pedal (January, 2010)  
Phase 1 – Vehicles Equipped with Accelerator Pedals manufactured by Denso Corporation

As communicated last Fall, the defect is the potential for an unsecured or incompatible driver's floor mat to interfere with the accelerator pedal and cause it to get stuck in the wide open position. A stuck open accelerator pedal may result in very high vehicle speeds and make it difficult to stop the vehicle, which could cause a crash, serious injury or death. **Toyota has determined that this defect does not exist in vehicles in which the driver's side floor mat is compatible with the vehicle and properly secured.**

*This notice is to provide you with remedy instructions for affected Camry and Camry Hybrid vehicles equipped with accelerator pedals manufactured by Denso Corporation ("Denso pedals"). A separate notice will be provided for Phase 2 of this recall, which will cover vehicles equipped with accelerator pedals manufactured by CTS Corporation ("CTS pedals").*

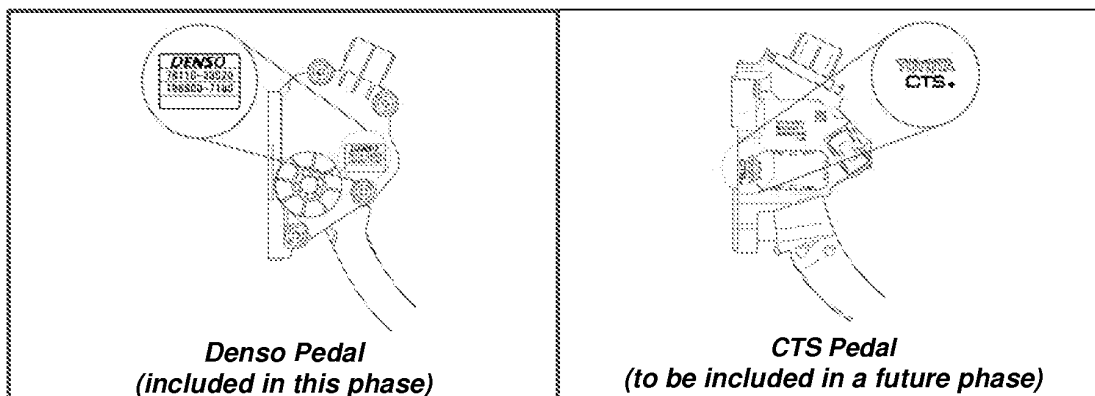

**Note:**

- **The name of the pedal manufacturer is printed (Denso) or embossed (CTS) on the upper sensor housing on the brake pedal side.**
- **This condition is separate from the Defect Information Report (DIR) filed on 1/21/2010 in reference to the possibility that certain CTS accelerator pedal mechanisms may, in rare instances, mechanically stick in a partially depressed position or return slowly to the idle position.**

The following vital information is provided to inform you and your staff of the owner notification phase of the campaign and your degree of involvement.

### **Campaign Remedy for Vehicles Equipped with Denso Pedals**

To make it less likely that an unsecured or incompatible driver's floor mat can interfere with the accelerator pedal, dealerships are requested to do the following:

- Modify both the rigid plastic accelerator pedal\* and the floor surface in the driver's foot-well.
- If the vehicle is equipped with a set of optional genuine Toyota All Weather Floor Mats (AWFM), it will be inspected to determine if the AWFM set is of an older design. If it is, the older design AWFMs for the driver and the front seat passenger positions will be replaced with newly designed mats.
- Before the vehicle is returned to the customer, inspect the front carpet and floor mat and clean them as appropriate.

As an additional measure independent of the vehicle-based recall remedy, you should also install a newly designed override system on **non-hybrid** Camry vehicles to provide an extra measure of confidence. This system will cut engine power in case of simultaneous application of both accelerator and brake pedals at certain speeds and driving conditions. **The Camry Hybrid already contains a fuel supply cut feature for Hybrid motor protection that achieves a similar result as the override system newly designed for the non-hybrid models.**

*\*Note:*

- *This notice does not apply to Camry vehicles equipped with a **factory installed metallic sports pedal** which are manufactured by Denso. Toyota is currently developing the remedy for those vehicles. We will notify involved vehicle owners as soon as the remedy is available.*
- *If the vehicle is equipped with an **accessory metallic sports pedal cover**, Toyota will need to remove the metallic sports pedal cover. Once the remedy is completed, due to the nature of the repair, the accessory sports pedal cover will not be reinstalled. The customer may contact the Customer Experience Center (1-800-331-4331) for additional details and reimbursement consideration.*

#### **1. Owner Notification Letter Mailing Date**

The owner notification will commence in early February, approximately one week after your dealership has been notified.

**This campaign will be launched in phases.**

- The first phase will include certain 2007 through 2010 model year Camry and Camry Hybrid vehicles equipped with Denso accelerator pedals. These owner letters will be mailed over a period of several weeks.
- Additional models, including Camrys equipped with a CTS accelerator pedal will be launched in later phases as the remedy is developed.
- Information on additional phases related to Camry (equipped with a CTS accelerator pedal), Avalon, Corolla, Highlander, Matrix, Prius, Tacoma, Tundra and Venza will be provided prior to the launch of these phases.

If your dealership is contacted by an owner of a Denso pedal equipped Camry who has not yet received a notification, please **verify eligibility by confirming through Dealer Daily/TIS prior to performing repairs**. Dealers should perform the repair as outlined in the attached Technical Instructions.

#### **2. Vehicles in Dealer Stock**

- As required by Federal law, dealers are not to deliver any new vehicles in their inventory, which are involved in a safety recall unless the defect has been remedied. However, because this defect does not exist in vehicles in which the driver's side floor mat is compatible with the vehicle and properly secured you may continue to sell new vehicles (with Denso pedals) that have not received the full remedy if you assure the driver's position floor mat is semi-permanently secured or place the front driver's and passenger's floor mats in the trunk on any vehicles in stock prior to sale or lease. Vehicle safety recall completion can be verified through TIS.
- *In order to assure established customers receive priority for the safety recall, we request that this campaign remedy be performed on in-stock Camry and Camry Hybrid vehicles just prior to vehicle delivery where possible.*
- **A VIN list containing vehicles in dealer stock will be provided shortly.**

**3. Dealer Summary Reports**

*The following SSC 90L Summary Reports will be provided shortly:*

- *The number of involved vehicles in your dealership’s primary marketing area for this phase*
- *The suggested initial parts order quantities for this phase*

**4. Number and Identification of Involved Vehicles**

There are approximately 787,000 Camry and Camry Hybrid vehicles (2007 through 2010 model year), equipped with Denso pedals.

MODEL	WMI	MY	VDS	VIN Range		
					Ranges	
CAMRY	4T1	2007	BE46K	U	[REDACTED]	- U [REDACTED]
			BK46K	U	[REDACTED]	- U [REDACTED]
		2008	BE46K	U	[REDACTED]	- U [REDACTED]
			BK46K	U	[REDACTED]	- U [REDACTED]
		2009	BE46K	U	[REDACTED]	- U [REDACTED]
			BK46K	U	[REDACTED]	- U [REDACTED]
	2010	BF3EK	U	[REDACTED]	- TBD	
		BK3EK	U	[REDACTED]	- TBD	
	JTN	2007	BE46K	3	[REDACTED]	- 3 [REDACTED]
			BK46K	3	[REDACTED]	- 3 [REDACTED]
		2008	BE46K	3	[REDACTED]	- 3 [REDACTED]
			BK46K	3	[REDACTED]	- 3 [REDACTED]
		2009	BE46K	3	[REDACTED]	- 3 [REDACTED]
			BK46K	3	[REDACTED]	- 3 [REDACTED]
2010		BF3EK	3	[REDACTED]	- 3 [REDACTED]	
		BK3EK	3	[REDACTED]	- 3 [REDACTED]	
CAMRY HYBRID	4T1	2007	BB46K	U	[REDACTED]	- U [REDACTED]
			BK46K	U	[REDACTED]	- U [REDACTED]
		2009	BB46K	U	[REDACTED]	- U [REDACTED]
			BB3EK	U	[REDACTED]	- TBD
	JTN	2007	BB46K	3	[REDACTED]	- 3 [REDACTED]
			BK46K	3	[REDACTED]	- 3 [REDACTED]
		2008	BB46K	3	[REDACTED]	- 3 [REDACTED]
			BK46K	3	[REDACTED]	- 3 [REDACTED]
		2009	BB46K	3	[REDACTED]	- 3 [REDACTED]
			BB3EK	3	[REDACTED]	- 3 [REDACTED]

**NOTE:**

- Not all vehicles in the VIN range are affected by this SSC.
- If your dealership is contacted by an owner of a Denso pedal equipped Camry who has not yet received a notification, please **verify eligibility by confirming through Dealer Daily/TIS prior to performing repairs. Please note, the customers with CTS accelerator pedals will be involved in a separate phase.**
- Dealers should perform the repair as outlined in the Technical Instructions found on TIS.

**5. Parts Ordering**

The necessary parts can be ordered through your dealership's facing PDC. Please refer to the table below and the Technical Instructions (located on TIS) for part number information.

To ensure that each Toyota Dealer has an adequate supply of service parts to complete customer vehicle repairs based on initial 90L mailing quantities and support repairs on new, pre-owned and TRAC vehicles in dealer inventory, NAPO and CAD have placed Manual Allocation codes on each of the following part numbers. Maximum quantity percentages will be increased as additional mailers are released. NAPO will release dealer orders as shown in the matrix below until further notice:

**Floor Surface Modification**

Part Number	Description	Dir QUP	Dir Max Order Qty	Max Qty released
04009-52106	*Tibia, Pad Kit	1	50	Up to 20% of Dir UIO
78118-41010	Stopper	10	50	Up to 20% of Dir UIO

\*Upper and Lower Tibia Pad

To support customers that have Genuine Toyota Camry All Weather Floor Mats, Toyota will be replacing the customer's existing driver and passenger side front floor mats using the correct color 2-piece mat set below:

**All Weather Floor Mat (AWFM) Replacement**

Part Number	Description	Color	Dir MaxOrder Qty
*PT908-0310W-02	2PC AWFM BLK CAMRY	Black	4
*PT908-0310W-14	2PC AWFM BRN CAMRY	Brown	1

Dealer Maximum Order quantities for these new All Weather Floor Mat part numbers are consistent with our historical sales. Manual Allocation Codes are on these two part numbers and dealer orders will be reviewed and released based on availability and dealer order history.

Any questions, request or concerns regarding the parameters established above should be directed to your regional representative.

\*AWFM's replaced under this campaign will be placed on Warranty Parts Recovery.

- To assure the AWFM's are rendered unusable, please cut them prior to return.
- Floor mats that are not returned will result in the claim being debited.
- If a customer has disposed of their older design Toyota genuine AWFM, he/she may receive the replacement AWFM's for the driver and front passenger seating positions upon proof-of-purchase of the original set. Please return a copy of the proof-of-purchase stapled to the repair order in an envelope in lieu of the actual AWFM for warranty parts recovery.

**IMPORTANT PARTS ORDERING REMINDER**

*Effective March 1, 2009, Safety Recall, Service Campaign (SSC/LSC) and Customer Support Program (CSP) parts do not earn Parts Return Credit Accrual and are not returnable under the Monthly Return Program.*

It is recommended that you order these parts based on appointments or immediate customer needs using a "Sell One-Buy One" ordering pattern. Please refer to PANT Bulletin 09-12 for additional details.

In the event the grommet area requires repair, a new repair part is available. Please refer to T-SB-0397-09 for additional information on grommet repair.

Part No.	Part Name	Qty/Unit
58297-50020	Retainer, Floor Clamp	Depending Upon Need

**6. Tools and Equipment and Materials**

In a separate shipment scheduled to arrive February 02, 2010, your dealership was sent a campaign tool kit. This kit included the required accelerator template and gauge, an orbital sander and a reciprocating saw.

When received, the campaign tool kit package will have a fluorescent (green, orange, yellow or pink) label like the sample seen below for easy identification.

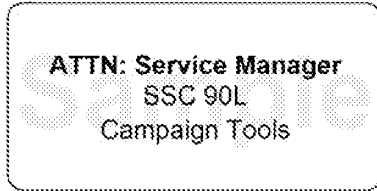

The additionally required tools and equipment are listed in the technical instructions found on TIS.

**7. Repair Procedures**

Refer to TIS for the appropriate Technical Instructions.

**NOTE: This campaign supersedes SSC 70F. Claims for SSC 70F will no longer be accepted.**

**8. Warranty Processor Instructions**

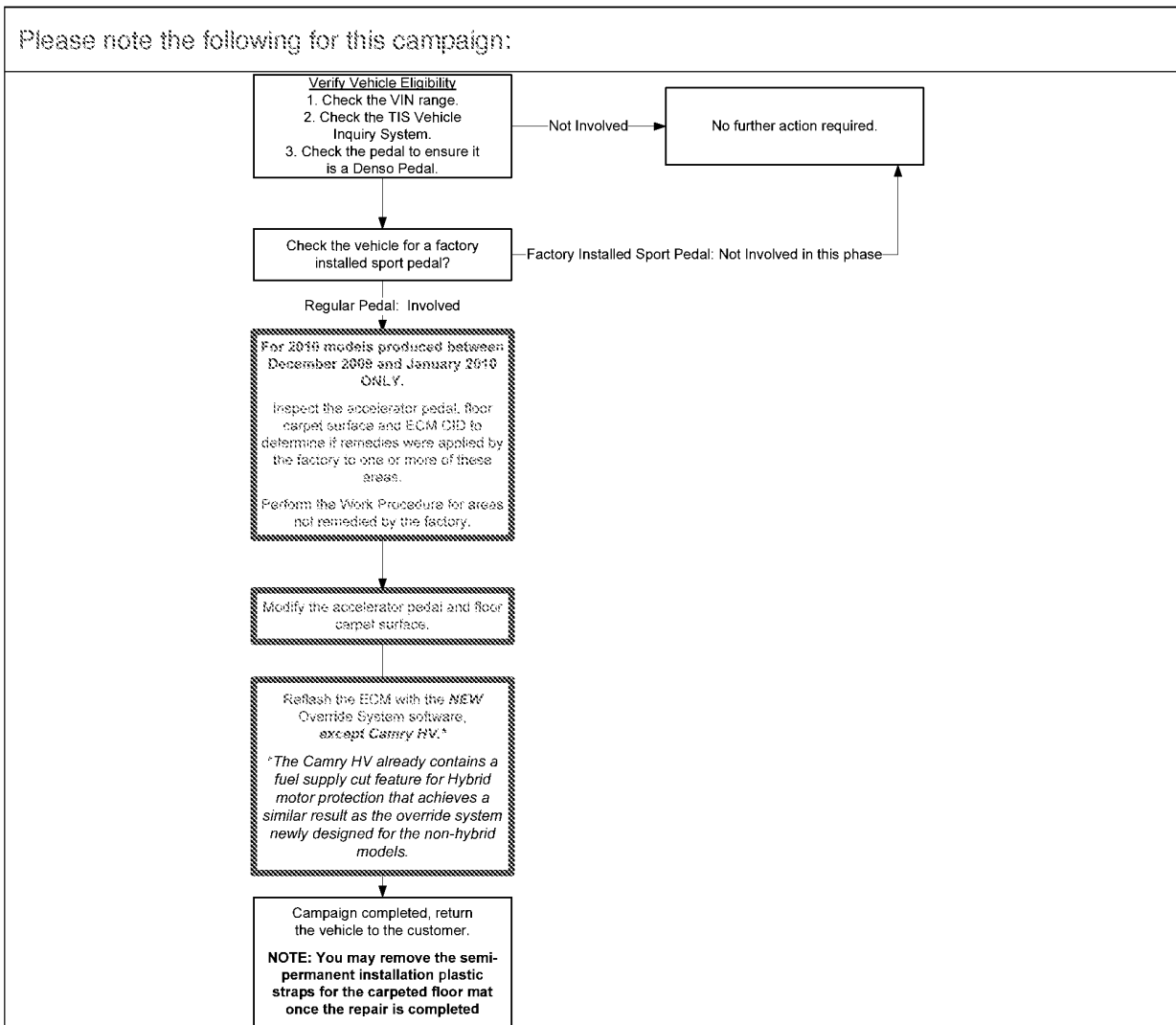

**(Warranty Processor Instructions Continued. . . )**

The operation codes to be used for this campaign are:

SSC #	Op. Code	Description	Flat Rate Hour
90L Camry <del>Non-Hybrid</del> Vehicles Equipped with Denso Pedals*	9911M9	1. Accelerator Pedal and Floor Surface Modification 2. Override System (reflash) installation <b>3. Remove the sound deadening material</b> <b>4. Replacement of the All Weather Floor Mat</b> 5. Inspect the front carpet and floor mat and clean them as appropriate.	2.1 hr/vehicle
	9911MA	1. Accelerator Pedal and Floor Surface Modification 2. Override System (reflash) installation <b>3. Remove the sound deadening material</b> 4. Inspect the front carpet and floor mat and clean them as appropriate.	2.1 hr/vehicle
	9911MB	1. Accelerator Pedal and Floor Surface Modification 2. Override System (reflash) installation <b>3. Replacement of the All Weather Floor Mat</b> 4. Inspect the front carpet and floor mat and clean them as appropriate.	2.0 hr/vehicle
	9911MC	1. Accelerator Pedal and Floor Surface Modification 2. Override System (reflash) installation 3. Inspect the front carpet and floor mat and clean them as appropriate.	2.0 hr/vehicle
90L Camry <del>Hybrid</del> Vehicles Equipped with Denso Pedals	9911MD	1. Accelerator Pedal and Floor Surface Modification <b>2. Remove the sound deadening material</b> <b>3. Replacement of the All Weather Floor Mat</b> 4. Inspect the front carpet and floor mat and clean them as appropriate.	1.6 hr/vehicle
	9911ME	1. Accelerator Pedal and Floor Surface Modification <b>2. Remove the sound deadening material</b> 3. Inspect the front carpet and floor mat and clean them as appropriate.	1.6 hr/vehicle
	9911MF	1. Accelerator Pedal and Floor Surface Modification <b>2. Replacement of the All Weather Floor Mat</b> 3. Inspect the front carpet and floor mat and clean them as appropriate.	1.5 hr/vehicle
	9911MG	1. Accelerator Pedal and Floor Surface Modification 2. Inspect the front carpet and floor mat and clean them as appropriate.	1.5 hr/vehicle

- **The Camry Hybrid already contains a fuel supply cut feature for Hybrid motor protection that achieves a similar result as the override system newly designed for the non-hybrid models. Claims filed for ECU Reprogramming on Camry Hybrid vehicles will be debited.**
- The above flat rate time includes 0.1 hour for administrative cost per unit.
- Additional materials used for repairing each vehicle (i.e., industrial tape, double-stick tape, replacement saw blades (amortized over several repairs), replacement sanding disks (amortized over several repairs), etc.) can be claimed as a sublet type “ZZ” at a rate of \$1.00 per vehicle.
- AWFM’s replaced under this campaign will be placed on Warranty Parts Recovery.
- The above flat rate time includes the necessary time to repair the floor carpet grommets on an as needed basis. Please refer to TSB 0397-09. If necessary, please provide replacement floor mat clips to the customer.
- If the vehicle is installed with an accessory accelerator pedal cover, the cost of the accessories accelerator pedal will be reimbursed under the sublet cost column. Utilize sublet type “CR” at a maximum of \$80.00 per vehicle.

**9. Customer Handling**

Please consider this campaign a great opportunity to focus on assuring customers that their safety remains Toyota's highest priority. Customers who receive the owner letter may contact your dealership with questions regarding the letter and/or campaign remedy. Please ensure that all customer contact personnel are aware of this campaign and know how to accurately answer customer's questions or how to direct the customer to someone that can. Please welcome them to your dealership and answer any questions that they may have. A Q&A is provided to assure a consistent message is communicated. In addition, please:

- Encourage owners of 2007 through 2010 Camry and Camry Hybrid vehicles who have not yet received the campaign remedy letter to take out any removable driver's floor mat and NOT replace it with any other floor mat until the safety recall (campaign) remedy has been completed on the vehicle.
- If a customer chooses not to remove the floor mat currently installed in his/her vehicle, they must make sure the floor mats are compatible for their model and model year. Also, they need to be sure they are properly secured using the appropriate retention device (clips). Driver's floor mats should never be stacked. Consumers should never place any floor mat (aftermarket or not) on top of another driver's floor mat. Mats should also not be flipped over with the bottom-side up. Information on proper floor mat installation can be found in the January 2010 Sales Hot Sheet and on <http://www.toyota.com/floormats>.
- Assist any customer who asks to verify correct floor mat application and secure installation.
- Advise owners of affected Avalon, Camry (equipped with a CTS pedal), Corolla, Highlander, Matrix, Prius, Tacoma, Tundra and Venza vehicles that Toyota is currently developing a campaign remedy. Customers should retain the all weather and/or carpeted driver's floor mat until the campaign remedy is available.
- Some of the Camry vehicles subject to SSC 90L Phase 1 (Potential Floor Mat Interference with Accelerator Pedal) are also subject to LSC 90K (VVT-i Oil Hose Replacement). It is important that your dealership perform all applicable SSC/LSC repairs in a single service visit and correctly submit the associated warranty claims.
- Customers with additional questions or concerns are asked to please contact the Toyota Customer Experience Center (1-888-270-9371).
- If an owner has previously paid for their vehicle's accelerator pedal and/or floor surface to be modified to address this specific condition, they are requested to mail a copy of the repair order, proof-of-payment, and proof-of-ownership to the following address for reimbursement consideration

Toyota Motor Sales, U.S.A., Inc  
Toyota Customer Experience Center, WC10  
19001 South Western Avenue  
Torrance, CA 90509

*Service Department:*

Since some customers may have misconceptions in relation to this campaign, a Job Aid has been provided. Please use this document when answering customer questions and explaining the appearance of the modified accelerator pedal. Two key elements of customer satisfaction and retention are to ensure you have time during the reception and write-up process to accurately address all of the customer's questions and concerns. Next, and most important, is a quality service delivery.

Make sure your delivery process includes:

- Assemble the paperwork and store it in a location that is easy to access
- The customer keys are organized and stored in a secure location
- Staffing allows you to have extra time to review the details of repairs
- Review the work completed
  - Pedal modification
  - Floor surface modification
  - Override system installation

*[Service Department continued...]*

- Review any approved customer pay maintenance or repair work performed outside the scope of the recall
- Review the “Customer Health Check” that was performed on their vehicle
- Review any multipoint inspection that was performed with the customer’s approval
- Present and explain the “Toyota Owner Card” to the customer
- Review proper floor mat installation utilizing the January 2010 Sales Hot Sheet
- Ask the customer if they have any questions or concerns. If necessary, direct them to the Toyota Customer Experience Center or <http://www.toyota.com/floormats>
- Offer to set the next appointment for scheduled maintenance for customer
- Request the customer’s vehicle to be staged for delivery
- Provide the keys to the customer and thank them for their business

*Sales Department:*

- Please refer to the Toyota Hot Sheet when answering questions and communicating floor mat installation and maintenance. Customers with other questions should be directed to a knowledgeable person in the service department.

Please review this entire package with your Service and Parts staff to familiarize them with the proper step-by-step procedures required to implement this Special Service Campaign.

Thank you for your cooperation.  
TOYOTA MOTOR SALES, U.S.A., INC.



**Certain 2007 through 2010 Model Year Camry Vehicles  
Potential Floor Mat Interference with Accelerator Pedal  
Safety Recall Campaign**

Please make an appointment with your local Toyota Dealer to have this important remedy completed.

[VIN]

Dear Toyota Owner:

This notice is being sent to you in accordance with the requirements of the National Traffic and Motor Vehicle Safety Act. Toyota has decided that a defect which relates to motor vehicle safety exists in certain 2007 through certain 2010 model year Camry vehicles.

**What is the Condition?**

- As we notified you earlier this past fall, the defect is the potential for an unsecured or incompatible driver's floor mat to interfere with the accelerator pedal and cause it to get stuck in the wide open position. A stuck open accelerator pedal may result in very high vehicle speeds and make it difficult to stop the vehicle, which could cause a crash, serious injury or death. Toyota has determined that this defect does not exist in vehicles in which the driver side floor mat is compatible with the vehicle and properly secured.

**What will Toyota do?**

- To make it less likely that an unsecured or incompatible driver's floor mat can interfere with the accelerator pedal on your vehicle, any Toyota dealer will remedy your vehicle at **NO CHARGE** to you. The remedy will entail modification to both the accelerator pedal and the floor surface in the driver's foot-well.
- If your vehicle is equipped with a set of optional genuine Toyota All Weather Floor Mats (AWFM), it will be inspected to determine if the AWFM set is of an older design. If it is, the older design AWFMs for the driver and the front seat passenger will be replaced with newly designed ones at **NO CHARGE** to you.
- Before the vehicle is returned to you, Toyota will inspect the driver's carpet and will clean it if necessary at **NO CHARGE** to you.

As an additional measure independent of the vehicle-based recall remedy, Toyota will install a newly designed override system in your vehicle to provide an extra measure of confidence. This system will cut engine power in case of simultaneous application of both accelerator and brake pedals at certain speeds and driving conditions. This installation will also be conducted at **NO CHARGE** to you.

**What should you do?**

***This is an important Safety Recall***

Please contact your authorized Toyota dealer to make appointment to have these important remedies performed on your vehicle as soon as possible.

The remedy will take approximately two hours. However, depending upon the dealer's work schedule, it may be necessary to make your vehicle available for a longer period of time.

Until these important remedies are completed, we request that you take out ***any removable*** driver's floor mat, place it in the trunk, and NOT replace it with any other floor mat until the campaign remedy has been implemented on your vehicle. ***If you have an optional genuine Toyota All Weather Floor Mat, please bring it to the dealership at the time of your remedy.***

In the event you choose not to take out your removable floor mat, Toyota strongly recommends that you ensure that the correct floor mat is being used, that it is properly installed and secured, that it is not flipped over with the bottom-side up, and that one floor mat is not stacked over another. Please visit <http://www.toyota.com/floormats> for additional information.

### **What should you do if you experience accelerator pedal interference?**

Should the vehicle continue to accelerate rapidly after releasing the accelerator pedal, this could be an indication of floor mat interference. If this occurs, Toyota recommends you take the following actions:

First, if it is possible and safe to do so, pull back the floor mat and dislodge it from the accelerator pedal; then pull over and stop the vehicle.

If the floor mat cannot be dislodged, then firmly and steadily step on the brake pedal with both feet. Do NOT pump the brake pedal repeatedly as this will increase the effort required to slow the vehicle.

Shift the transmission gear selector to the Neutral (N) position and use the brakes to make a controlled stop at the side of the road and turn off the engine.

If unable to put the vehicle in Neutral, turn the engine OFF, or to ACC. This will not cause loss of steering or braking control, but the power assist to these systems will be lost.

-If the vehicle is equipped with an Engine Start/Stop button, firmly and steadily push the button for at least three seconds to turn off the engine. Do NOT tap the Engine Start/Stop button.

-If the vehicle is equipped with a conventional key-ignition, turn the ignition key to the ACC position to turn off the engine. Do NOT remove the key from the ignition as this will lock the steering wheel.

### **What if you have other questions?**

**Please visit <http://www.toyota.com/floormats> for further information.** Your local Toyota dealer will be more than happy to answer any of your questions as well. If you require further assistance, you may contact the **Toyota Customer Experience Center at 1-888-270-9371** Monday through Friday, 5:00 am to 6:00 pm, or Saturday 7:00 am through 4:00 pm Pacific Standard Time. Your satisfaction is extremely important to us. In the event you are not satisfied with the modification of your accelerator pedal after it is completed, a replacement accelerator pedal will be offered beginning around April 2010. Customers who have had the remedy completed will have the opportunity to receive a new pedal at no charge if desired.

If you believe that the dealer or Toyota has failed or is unable to remedy the defect within a reasonable time, you may submit a complaint to the Administrator, National Highway Traffic Safety Administration, 1200 New Jersey Avenue, S.E., Washington, D.C. 20590; or call the toll-free Vehicle Safety Hotline at 1-888-327-4236 (TTY: 1-800-424-9153) or go to <http://www.safercar.gov>.

### **What if you have previously paid for your vehicle's accelerator pedal or floor surface to be modified to address the same condition described above?**

If you have previously paid for your vehicle's accelerator pedal or floor surface to be modified to address the same condition described above, please mail a copy of your repair order, proof-of-payment, and proof-of-ownership to the following address for reimbursement consideration

Toyota Motor Sales, U.S.A., Inc  
Toyota Customer Experience, WC10  
19001 South Western Avenue  
Torrance, CA 90509

If you are a vehicle lessor, Federal law requires that any vehicle lessor receiving this recall notice must forward a copy of this notice to the vehicle lessee within ten days of your receipt of this letter.

We have sent this notice in the interest of your continued satisfaction with our products.

Thank you for driving a Toyota.

Sincerely,

TOYOTA MOTOR SALES, U.S.A., INC.

|

**Certain 2007 through 2010 Model Year Camry Hybrid Vehicles  
Potential Floor Mat Interference with Accelerator Pedal  
Safety Recall Campaign**

Please make an appointment with your local Toyota Dealer to have this important remedy completed.

[VIN]

Dear Toyota Owner:

This notice is being sent to you in accordance with the requirements of the National Traffic and Motor Vehicle Safety Act. Toyota has decided that a defect which relates to motor vehicle safety exists in certain 2007 through certain 2010 model year Camry Hybrid vehicles.

**What is the Condition?**

- As we notified you earlier this past fall, the defect is the potential for an unsecured or incompatible driver's floor mat to interfere with the accelerator pedal and cause it to get stuck in the wide open position. A stuck open accelerator pedal may result in very high vehicle speeds and make it difficult to stop the vehicle, which could cause a crash, serious injury or death. Toyota has determined that this defect does not exist in vehicles in which the driver side floor mat is compatible with the vehicle and properly secured.

**What will Toyota do?**

- To make it less likely that an unsecured or incompatible driver's floor mat can interfere with the accelerator pedal on your vehicle, any Toyota dealer will remedy your vehicle at **NO CHARGE** to you. The remedy will entail modification to both the accelerator pedal and the floor surface in the driver's foot-well.
- If your vehicle is equipped with a set of optional genuine Toyota All Weather Floor Mats (AWFM), it will be inspected to determine if the AWFM set is of an older design. If it is, the older design AWFM's for the driver and the front seat passenger will be replaced with newly designed ones at **NO CHARGE** to you.
- Before the vehicle is returned to you, Toyota will inspect the driver's carpet and will clean it if necessary at **NO CHARGE** to you.

As an additional measure independent of the vehicle-based recall remedy, Toyota will install a newly designed override system on select Camry models to provide an extra measure of confidence. This system will reduce engine power in case of simultaneous application of both accelerator and brake pedals at certain speeds and driving conditions. ***The Camry Hybrid already contains a fuel supply cut feature for Hybrid motor protection that achieves a similar result as the override system newly designed for the non-hybrid models.***

**What should you do?**

***This is an important Safety Recall***

Please contact your authorized Toyota dealer to make appointment to have these important remedies performed on your vehicle as soon as possible.

The remedy will take approximately two hours. However, depending upon the dealer's work schedule, it may be necessary to make your vehicle available for a longer period of time.

Until these important remedies are completed, we request that you take out ***any removable*** driver's floor mat, place it in the trunk, and NOT replace it with any other floor mat until the campaign remedy has been implemented on your vehicle. ***If you have an optional genuine Toyota All Weather Floor Mat, please bring it to the dealership at the time of your remedy.***

In the event you choose not to take out your removable floor mat, Toyota strongly recommends that you ensure that the correct floor mat is being used, that it is properly installed and secured, that it is not flipped over with the bottom-side up, and that one floor mat is not stacked over another. Please visit <http://www.toyota.com/floormats> for additional information.

### **What should you do if you experience accelerator pedal interference?**

Should the vehicle continue to accelerate rapidly after releasing the accelerator pedal, this could be an indication of floor mat interference. If this occurs, Toyota recommends you take the following actions:

First, if it is possible and safe to do so, pull back the floor mat and dislodge it from the accelerator pedal; then pull over and stop the vehicle.

If the floor mat cannot be dislodged, then firmly and steadily step on the brake pedal with both feet. Do NOT pump the brake pedal repeatedly as this will increase the effort required to slow the vehicle.

Shift the transmission gear selector to the Neutral (N) position and use the brakes to make a controlled stop at the side of the road and turn off the engine.

If unable to put the vehicle in Neutral, turn the engine OFF by firmly and steadily pushing the Engine Start/Stop button for at least three seconds. Do NOT tap the Engine Start/Stop button. This will not cause loss of steering or braking control, but the power assist to these systems will be lost.

### **What if you have other questions?**

**Please visit <http://www.toyota.com/floormats> for further information.** Your local Toyota dealer will be more than happy to answer any of your questions as well. If you require further assistance, you may contact the **Toyota Customer Experience Center at 1-888-270-9371** Monday through Friday, 5:00 am to 6:00 pm, or Saturday 7:00 am through 4:00 pm Pacific Standard Time. Your satisfaction is extremely important to us. In the event you are not satisfied with the modification of your accelerator pedal after it is completed, a replacement accelerator pedal will be offered beginning around April 2010. Customers who have had the remedy completed will have the opportunity to receive a new pedal at no charge if desired.

If you believe that the dealer or Toyota has failed or is unable to remedy the defect within a reasonable time, you may submit a complaint to the Administrator, National Highway Traffic Safety Administration, 1200 New Jersey Avenue, S.E., Washington, D.C. 20590; or call the toll-free Vehicle Safety Hotline at 1-888-327-4236 (TTY: 1-800-424-9153) or go to <http://www.safercar.gov>.

### **What if you have previously paid for your vehicle's accelerator pedal or floor surface to be modified to address the same condition described above?**

If you have previously paid for your vehicle's accelerator pedal or floor surface to be modified to address the same condition described above, please mail a copy of your repair order, proof-of-payment, and proof-of-ownership to the following address for reimbursement consideration

Toyota Motor Sales, U.S.A., Inc  
Toyota Customer Experience, WC10  
19001 South Western Avenue  
Torrance, CA 90509

If you are a vehicle lessor, Federal law requires that any vehicle lessor receiving this recall notice must forward a copy of this notice to the vehicle lessee within ten days of your receipt of this letter .

We have sent this notice in the interest of your continued satisfaction with our products.

Thank you for driving a Toyota.

Sincerely,

TOYOTA MOTOR SALES, U.S.A., INC.



Safety Recall 90L - Phase 1  
Certain 2007 – 2010 Model Year Toyota Camry and Camry Hybrid Vehicles  
Potential Floor Mat Interference with Accelerator Pedal Q&A  
February, 2010

**Q1: What is the condition?**

A1: As communicated last Fall, the defect is the potential for an unsecured or incompatible driver's floor mat to interfere with the accelerator pedal and cause it to get stuck in the wide open position. A stuck open accelerator pedal may result in very high vehicle speeds and make it difficult to stop the vehicle, which could cause a crash, serious injury or death. ***Toyota has determined that this defect does not exist in vehicles in which the driver side floor mat is compatible with the vehicle and properly secured.***

***This phase will include Camry and Camry HV vehicles equipped with accelerator pedals which do not require the installation of the "Reinforcement Bar". (Refer to Press Release issued Feb. 1<sup>st</sup> 2010, and the separate Accelerator Pedal Q&A)***

***Note: Camry vehicles involved in this Safety Recall and equipped with an accelerator pedal that require the installation of the "Reinforcement Bar" will be included in a separate phase to be launched shortly.***

**Q2: What is Toyota going to do for vehicles affected by Safety Recall 90L Phase 1?**

A2: To make it less likely that an unsecured or incompatible driver's floor mat can interfere with the accelerator pedal, any authorized Toyota dealer will modify both the rigid plastic accelerator pedal and the floor surface in the driver's foot-well.

If the vehicle is equipped with a set of optional genuine Toyota All Weather Floor Mats (AWFM), it will be inspected to determine if the AWFM set is of an older design. If it is, the older design AWFM's for the driver and the front seat passenger positions will be replaced with newly designed AWFM's.

As an additional measure independent of the vehicle-based recall remedy, Toyota will install a newly designed override system on Camry vehicles to provide an extra measure of confidence. This system will cut engine power in case of simultaneous application of both accelerator and brake pedals at certain speeds and driving conditions.

**Q2a: Why aren't all Camry vehicles involved in the Safety Recall included in this phase?**

A2a: Toyota filed a separate Defect Information Report on January 21, 2010 covering vehicles that require the installation of the reinforcement bar (Safety Recall A0A). Vehicles that also require Safety Recall A0A will be launched in a separate phase shortly.

In addition, certain Camry vehicles are factory equipped with a metallic sports pedal. Toyota is currently developing the remedy for this type of pedal.

**Q2b: When will Toyota launch this Safety Recall for the remaining vehicles that also require the reinforcement bar?**

A2b: The exact launching timing for the recall has not yet been determined, although Toyota hopes to do so shortly. Additional information will be released as it becomes available.

**Q2c: Is there a way to determine if a vehicle is involved in this phase or in a separate phase?**

A2c: The identification is printed or embossed on the upper sensor housing on the brake pedal side. Any authorized Toyota dealer can assist customers determine if a specific vehicle is involved in this phase or not.

**Q3: Why are vehicles with factory installed metallic accelerator pedals (“sports pedal”) not included in this phase?**

A3: Toyota is currently developing the remedy for Camry vehicles equipped with a factory installed metallic sports pedal. We will notify involved vehicle owners as soon as the remedy is available.

**Q3a: What if a vehicle is equipped with a metallic sports pedal cover? Will the repair be performed on my vehicle?**

A3a: Toyota will need to remove the metallic sports pedal cover. Once the remedy is completed, due to the nature of the repair, we will not be able to reinstall the sports pedal cover. Please contact the Customer Experience Center (1-800-331-4331) for additional details and reimbursement consideration.

**Q4: Can you provide me with additional information regarding the override system?**

A4: As an additional measure independent of the vehicle-based recall remedy, Toyota will install a newly designed override system on the Toyota Camry to provide an extra measure of confidence. This system will cut engine power in case of simultaneous application of both accelerator and brake pedals at certain speeds and driving conditions. The Camry Hybrid, as well as other hybrid vehicles such as the Prius, already contains a fuel supply cut feature for Hybrid motor protection that achieves a similar result as the override system newly designed for the non-hybrid models.

**Q4a: Why isn't Toyota installing the override system on Camry Hybrid vehicles as a part of this remedy?**

A4a: The Camry Hybrid already contains a fuel supply cut feature for Hybrid motor protection that achieves a similar result as the override system newly designed for the non-hybrid models.

**Q4b: Will Toyota be installing the override system on Camry vehicles involved in the separate phase?**

A4b: Yes.

**Q5: What should owners do until they have the recall remedy performed?**

A5: Toyota has determined that the pedal entrapment can only occur in vehicles where the driver's side floor mat is not compatible with the vehicle and/or not properly secured.

To help reduce the risk of incorrect floor mat installation and/or application, we request that customers take out any **removable** driver's floor mat and NOT replace it with any other floor mat until the safety recall (campaign) remedy has been completed on the vehicle. After the campaign remedy has been completed, only floor mats designed specifically for the vehicle and which are properly secured should be installed on the driver's floor.

**Q6: What if a customer chooses not to remove the floor mat currently installed in his/her vehicle, but would like to verify the installation and applicability?**

A6: To help reduce the risk of incorrect floor mat installation and/or application, we request that customers take out any **removable** driver's floor mat and NOT replace it with any other floor mat until the safety recall (campaign) remedy has been completed on the vehicle. If the customer chooses not to take out the floor mat, please direct the customer to his/her local Toyota dealership's Parts or Service Department to verify whether the Toyota floor mat is designed specifically for the vehicle and to ensure that it is correctly installed. The floor mat should be removed before driving to the dealership. The dealership will ensure that the vehicle is equipped with the proper floor mat and that it is properly installed. After the campaign remedy has been completed, only floor mats designed specifically for the vehicle and which are properly secured should be installed on the driver's floor.

**Q6a: What if a customer disposed of his/her Toyota genuine All Weather Floor Mat (AWFM)? Will he/she still receive a newly designed one?**

A6a: If a customer has disposed of an older design Toyota genuine All Weather Floor Mat (AWFM), he/she may receive the replacement AWFM's for the driver and front passenger seating positions upon proof-of-purchase of the original set.

**Q7: What if a floor mat is an aftermarket rubberized floor mat?**

A7: Driver's floor mat interference is possible if the floor mat is incompatible or incorrectly installed. Therefore, consumers need to make sure the floor mats are compatible for his/her model and model year. Also, they need to be sure they are properly secured using the appropriate retention device (clips). Driver's floor mats should never be stacked. Consumers should never place any floor mat – aftermarket or not on top of another driver's floor mat. Floor mats should also not be flipped over with the bottom-side up.

**Q7a: When will Toyota genuine All Weather Floor Mats (AWFM) be available for purchase?**

A7a: The newly designed Toyota genuine All Weather Floor Mats (AWFM) will become available for purchase again in March, 2010, for the Camry. Other models will be available in the following months. Please check with your Toyota dealership regularly for specific availability dates.

**Q8: What if a driver experiences accelerator pedal interference. What should they do?**

A8: Should the vehicle continue to accelerate rapidly after releasing the accelerator pedal, this could be an indication of floor mat interference. If this occurs, Toyota recommends the driver take the following actions:

- First, if it is possible and safe to do so, pull-back the floor mat and dislodge it from the accelerator pedal; then pull over and stop the vehicle.
- If the floor mat cannot be dislodged, then firmly and steadily step on the brake pedal with both feet. Do not pump the brake pedal repeatedly as this will increase the effort required to slow the vehicle.
- Shift the transmission gear selector to the Neutral (N) position and use the brakes to make a controlled stop at the side of the road and turn off the engine.
- If unable to put the vehicle in Neutral, turn the engine OFF. This will not cause loss of steering or braking control, but the power assist to these systems will be lost.
  - If the vehicle is equipped with an Engine Start/Stop button, firmly and steadily push the button for at least three seconds to turn off the engine. Do NOT tap the Engine Start/Stop button.
  - If the vehicle is equipped with a conventional key-ignition, turn the ignition key to the ACC position to turn off the engine. Do NOT remove the key from the ignition as this will lock the steering wheel.

**Q9: Are there any other Toyota or Lexus vehicles involved?**

A9: As outlined in the Consumer Advisory issued by NHTSA and Toyota, the following vehicles are involved:

**Lexus**

2007 – 2010 ES

2006 – 2010 IS

**Toyota**

2005 – 2010 Avalon

2007 – 2010 Camry & Camry Hybrid

2004 – 2009 Prius

2005 – 2010 Tacoma

2007 – 2010 Tundra

2009 - 2010 Corolla

2009 - 2010 Matrix

2009 - 2010 Venza

2008 - 2010 Highlander & Highlander Hybrid

**Q9a: Will the other Toyota and Lexus vehicles listed in the Consumer Advisory receive the same safety recall remedy?**

A9a: We are currently in the process of developing the remedies for the remaining vehicles. We will notify owners as soon as the remedy for their vehicle is available.

**Q9b: When will the remedy for the remaining vehicles be completed?**

A9b: We are currently in the process of developing the remedies for the remaining models, including Camrys equipped with a factory installed metallic sports pedal. We anticipate it will take several months to develop all of those remedies.

**Q9c: What should customers do if his/her vehicle is involved in this phase of the Safety Recall, but they haven't received his/her owner letter?**

A9c: Toyota will begin mailing Safety Recall Notices by first class mail to certain '07 - '10 Camry owners starting in early February, 2010. The owner letters will be spread over several months consistent with parts supply and repair capacity. We ask customers for their patience as we mail the letters.

Until these important remedies are completed, to help reduce the risk of incorrect floor mat installation and/or application, we request that customers take out any **removable** driver's floor mat and NOT replace it with any other floor mat until the safety recall (campaign) remedy has been completed on the vehicle. After the campaign remedy has been completed, only floor mats designed specifically for the vehicle and which are properly secured should be installed on the driver's floor.

In the event a customer chooses not to take out the removable floor mat, Toyota strongly recommends that the customer ensure that the correct floor mat is being used, that it is properly installed and secured, that it is not flipped over with the bottom-side up, and that one floor mat is not stacked over another. Please visit <http://www.toyota.com/floormats> for additional information.

**Q9d: Do customers need the owner letter to set-up an appointment with his/her Toyota dealership?**

A9d: If the safety recall remedy has been launched for the specific model and accelerator pedal, customers will not need the owner letter to set up an appointment with his/her Toyota dealership.

**Q10: What if an owner has additional questions or concerns?**

A10: Owners with questions or concerns are asked to please contact the Toyota Customer Experience Center at 1-888-270-9371 Monday through Friday, 5:00 am to 6:00 pm, or Saturday 7:00 am through 4:00 pm Pacific Standard Time. They may also consult the information posted at <http://www.toyota.com/floormats>.

**Q10a: What if an owner has previously paid for repairs to modify the vehicle's accelerator pedal and/or floor surface to address this condition?**

A10a: Owners that have previously paid for their vehicle's accelerator pedal and/or floor surface to be modified to address this specific condition are requested to mail a copy of the repair order, proof-of-payment, and proof-of-ownership to the following address for reimbursement consideration

Toyota Motor Sales, U.S.A., Inc  
Toyota Customer Experience Center, WC10  
19001 South Western Avenue  
Torrance, CA 90509

**Q10b: What if an owner has experienced unintended acceleration and his/her vehicle is not involved in either of these safety recalls?**

A10b: If an owner of a Toyota vehicle that is not covered by these recalls believes that he/she has experienced unintended acceleration with their vehicle, they are requested to immediately contact an authorized Toyota dealer. The Toyota dealer will evaluate the consumer's complaint.



**Q10c: Why aren't other models included in this safety recall?**

A10c: Other models are not involved in this safety recall. Toyota does not have reason to believe that the vehicle's accelerator pedal or floor is configured in a way that creates an unreasonable risk of pedal entrapment. Nevertheless, there is a risk of accelerator pedal entrapment in any vehicle if inappropriate or unsecured floor mats are in use. Please check the driver's side floor area and remove any improperly installed floor mat. Never use an all weather floor mat on top of a removable carpeted mat, never install an all weather floor mat upside down, and never use an all weather floor mat that is incompatible with your vehicle.

Note: Please reference the specific Q&A for models requiring the reinforcement bar (included in the separate Safety Recall).

**Q11: Will a rental (TRAC) vehicle be made available for customers by Toyota for this Safety Recall?**

A11: The safety recall remedy will take approximately two hours to complete. Therefore a rental vehicle will not be provided.

**Q11a: What if a customer has experienced issues with his/her vehicle and is not willing to drive the vehicle until the remedy has been completed?**

A11a: The defect is the potential for an unsecured or incompatible driver's floor mat to interfere with the accelerator pedal and cause it to get stuck in the wide open position. **Toyota has determined that this defect does not exist in vehicles in which the driver side floor mat is compatible with the vehicle and is properly secured.** Until the safety recall remedy is performed on the vehicle, we request that customers take out any removable floor mat.

**Q12: What will the modified accelerator pedal look like?**

A12: The accelerator pedal will be modified to slightly decrease the overall foot pad and pedal arm length. Any local Toyota dealer will be more than happy to go over the entire repair with the customer. We ask that they make an appointment as soon as possible.

**Q12a: What if a customer is not satisfied with the appearance of the modified accelerator pedal?**

A12a: The change in appearance to the pedal is not noticeable once it is installed in a vehicle. However, in the event a customer is not satisfied, a replacement accelerator pedal will be offered beginning around April, 2010. Customers who have had the remedy completed will have the opportunity to receive a replacement pedal at no charge if desired.

**Q12b: Can I wait to have the accelerator pedal replaced with a newly designed one rather than have my current accelerator pedal modified?**

A12b: Customer safety is important to Toyota. We ask that customers have the pedal modified as soon as possible to make the vehicle more resistant to an unsecured or incompatible driver's floor mat interfering with the accelerator pedal. Once a newly designed accelerator pedal is available, if the customer is not satisfied with the appearance of the modified pedal, they may request the pedal to be replaced.

**Q12c: Will Toyota send another owner letter when the newly designed accelerator pedal becomes available?**

A12c: There will not be another owner letter sent when the newly designed accelerator pedal is available. If customers are not satisfied with the appearance of the modified accelerator pedal, we ask that they check with his/her dealership in a few months and to see if the newly designed pedal is available.

**Q13: Will Toyota clean the vehicle carpet for those owners that followed the Consumer Safety Advisory and removed his/her floor mats?**

A13: Your local Toyota dealership will inspect and clean the driver's carpet and floor mat as appropriate.

**TECHNICAL INSTRUCTIONS**  
**FOR**  
**SAFETY RECALL 90L**  
**DENSO ACCELERATOR PEDAL MODIFICATION**  
**2007 – 2010 MODEL YEAR CAMRY**

# I. OPERATION FLOW CHART

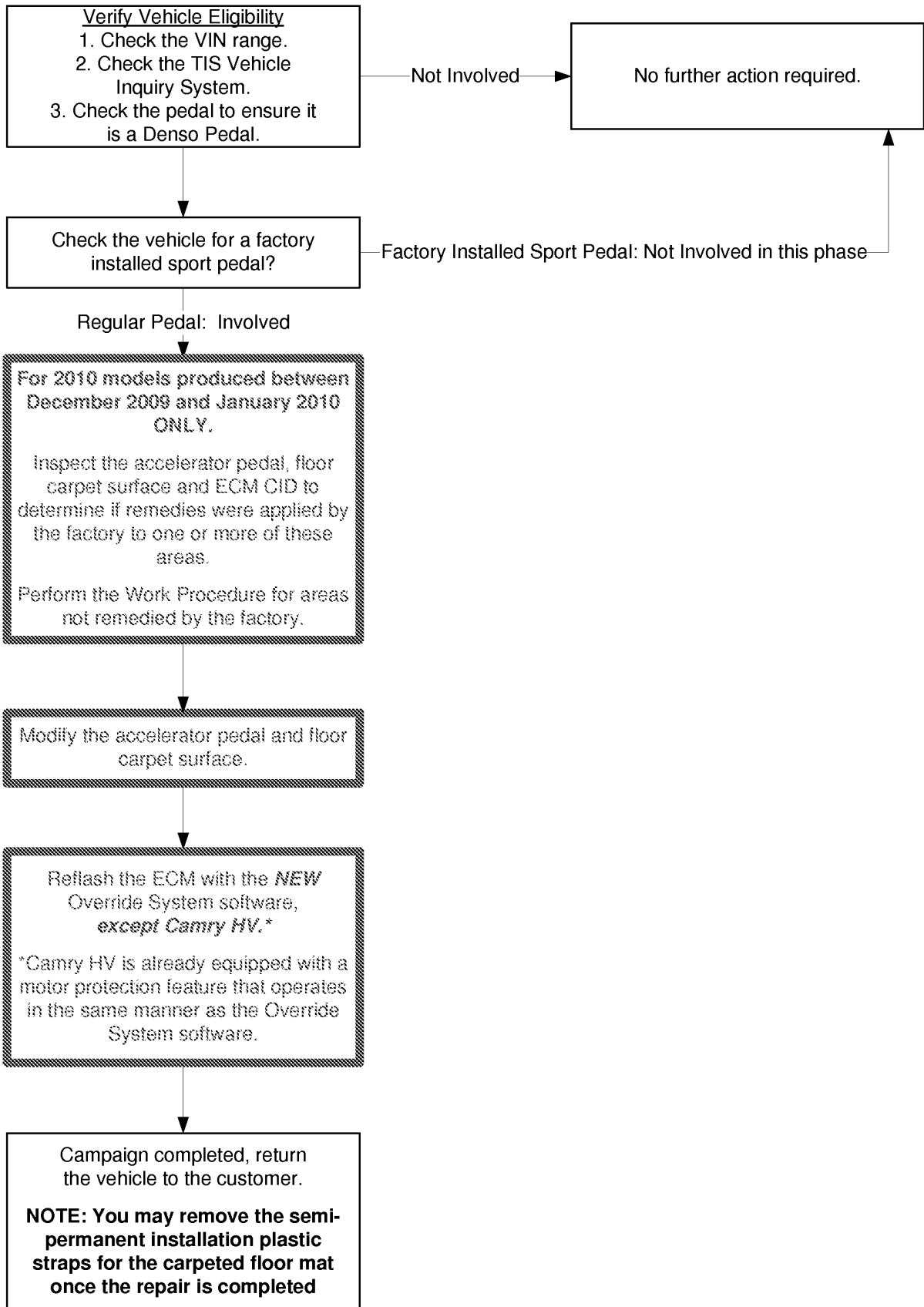

## II. IDENTIFICATION OF AFFECTED VEHICLES

### A. AFFECTED VIN RANGE

Model	WMI	Year	VIN Range	
			VDS	Range
CAMRY	4T1	2007	BB46K	U [REDACTED] - U [REDACTED]
			BE46K	U [REDACTED] - U [REDACTED]
			BK46K	U [REDACTED] - U [REDACTED]
		2008	BB46K	U [REDACTED] - U [REDACTED]
			BE46K	U [REDACTED] - U [REDACTED]
			BK46K	U [REDACTED] - U [REDACTED]
		2009	BB46K	U [REDACTED] - U [REDACTED]
			BE46K	U [REDACTED] - U [REDACTED]
			BK46K	U [REDACTED] - U [REDACTED]
		2010	BB3EK	U [REDACTED] - TBD
			BF3EK	U [REDACTED] - TBD
			BK3EK	U [REDACTED] - TBD
	JTN	2007	BB46K	3 [REDACTED] - 3 [REDACTED]
			BE46K	3 [REDACTED] - 3 [REDACTED]
			BK46K	3 [REDACTED] - 3 [REDACTED]
		2008	BB46K	3 [REDACTED] - 3 [REDACTED]
			BE46K	3 [REDACTED] - 3 [REDACTED]
			BK46K	3 [REDACTED] - 3 [REDACTED]
		2009	BB46K	3 [REDACTED] - 3 [REDACTED]
			BE46K	3 [REDACTED] - 3 [REDACTED]
			BK46K	3 [REDACTED] - 3 [REDACTED]
		2010	BB3EK	3 [REDACTED] - TBD
			BF3EK	3 [REDACTED] - TBD
			BK3EK	3 [REDACTED] - TBD

#### NOTE:

- Check the TIS Vehicle Inquiry System to confirm the VIN is involved in this SSC, and that the campaign has not already been completed prior to dealer shipment or by another dealer.
- TMS warranty will not reimburse dealers for repairs conducted on vehicles that are not affected or were completed by another dealer.

#### Important Sport Pedal Information

Sport Pedal Type	Involvement	Method of Identification	Action
Dealer/Port Installed Sport Pedal Cover Accessory	Involved	Plastic pedal arm	Notify ASM, Remove pedal cover and perform campaign. Do not reinstall the pedal cover after modification. Reimburse customer for the cost of the sport pedal cover accessory.
Factory Installed Sport Pedal	Not involved in this phase	Metal pedal arm	Notify ASM, Return vehicle to customer.

## III. PREPARATION

### A. PARTS

Part Number	Part Description	Quantity
04009-52106	Tibia Pad	1
78118-41010	Rubber Pad	1

**B. TOOLS & EQUIPMENT**

- Dust mask
- Hair dryer or
- Low temperature heat gun
- Hand file
- Hack saw
- Orbital sander \*
- Protective eyewear
- Protective work gloves
- Reciprocating Saw \*
- Scribe
- Standard hand tools
- Techstream
- Torque wrench
- Workbench with vise

\* One orbital sander and one reciprocating saw will be provided to each dealership.

**C. ACCELERATOR PEDAL TEMPLATE & GAUGE**

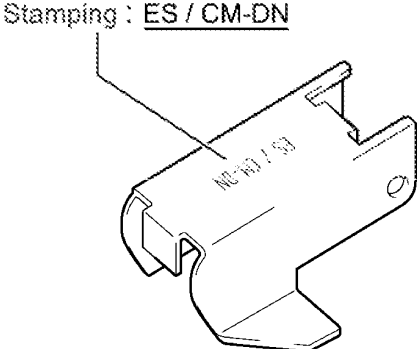
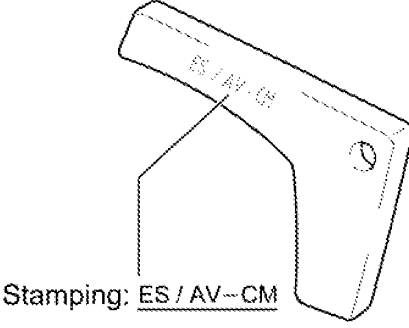
Cutting Template (Color: Silver) ** Application: DENSO Accelerator Pedal	Shape Gauge (Color: Silver) ** Application: All Accelerator Pedals
	

\*\* One DENSO cutting template and one shape gauge will be provided to each dealership.

**D. MATERIALS**

- Bubble wrap
- Double sided tape – (3/4" wide Scotch ® Heavy Duty Mounting Tape 110-Long)
- Industrial tape – (2" wide Gorilla Tape ® )
- Masking tape
- Sandpaper 400 grit
- Shop cloth

**IV. BACKGROUND**

In early October, Toyota announced it will initiate a Safety Recall Campaign (Special Service Campaign) for potential floor mat interference with the accelerator pedal. The condition involves the potential for an unsecured or incompatible driver's floor mat to interfere with the accelerator pedal and cause it to get stuck in the wide open position.

- The accelerator pedal will be modified to reduce the risk of an unsecured or incompatible floor mat from interfering with the accelerator pedal.
- Foam pads underneath the carpet in the accelerator pedal area will also be removed and/or replaced to modify the shape of the floor.
- Vehicles equipped with the optional genuine Toyota All Weather Floor Mats (AWFM) will be inspected to determine if the AWFM set is of an older design. If it is, the older design AWFM for the driver and the front passenger will be replaced with newly designed ones.
- Finally, the ECM will be reflashed with newly designed software to provide customers an extra measure of confidence. This reflash will allow the system to cut engine power in case of simultaneous application of both the accelerator and brake pedals during certain driving speeds.
- This phase will include 2007 – 2010 Camry vehicles equipped with a Denso accelerator pedal only.
- Owners of vehicles equipped with the CTS pedal will receive a different owner letter and the CTS equipped vehicles will have a separate repair procedure. Due to pedal differences it is vital that only Denso pedals are repaired in this phase.

# V. WORK PROCEDURE

## A. COMPONENTS

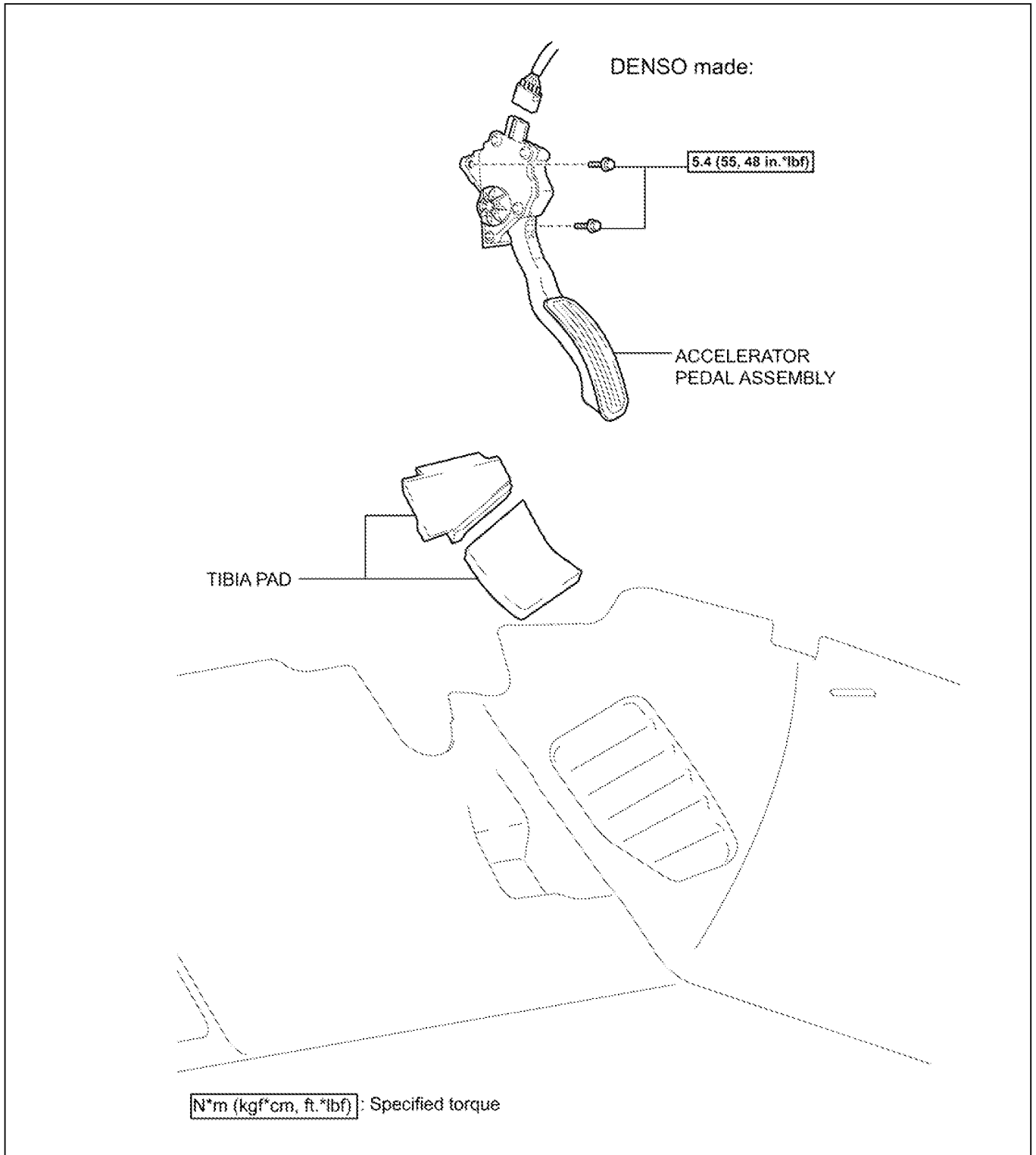

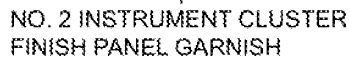
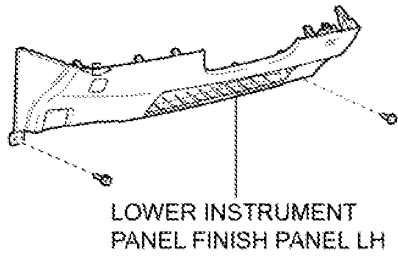

**for Automatic Transaxle:**

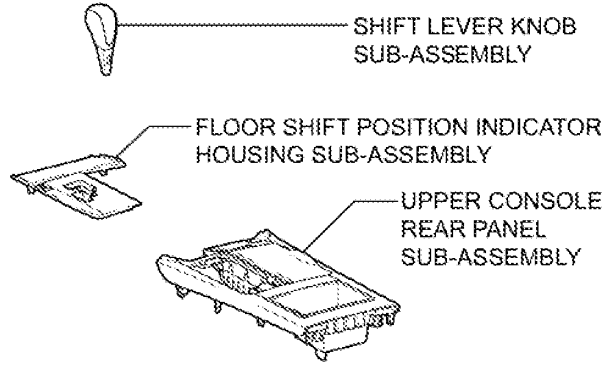

**for Manual Transaxle:**

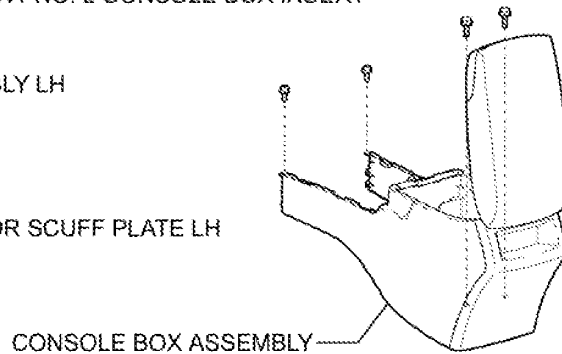
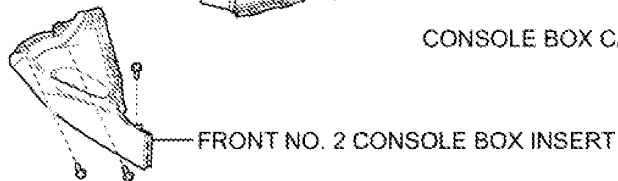
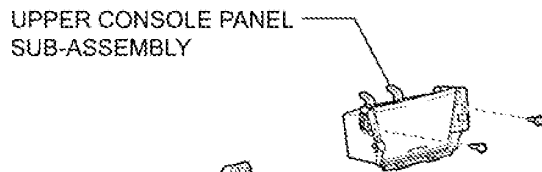
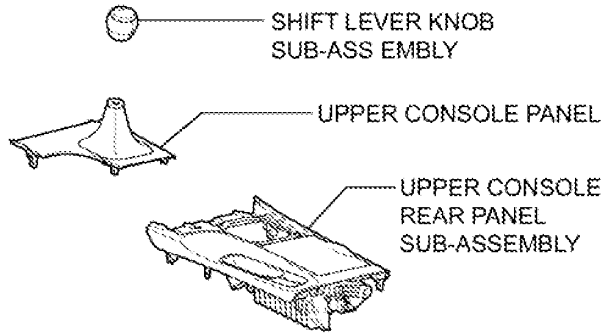

**B. PRELIMINARY INSPECTION FOR 2010 MODELS ONLY**



- The following inspection procedure is to determine if some 2010 models produced between December 2009 and January 2010 may have had remedies applied to the accelerator pedal, floor carpet or ECM CID by the factory.
- If applicable, perform the Work Procedure **ONLY** for areas **NOT** remedied by the factory.

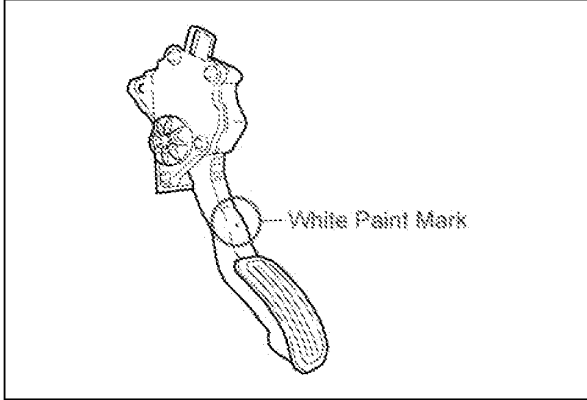

**1. INSPECT THE ACCELERATOR PEDAL ASSEMBLY**

- a) Verify if the accelerator pedal assembly has a white paint mark in the location shown.

**With White Paint Mark:**

- The accelerator pedal remedy has been applied by the factory, **NO** modification is required.

**NO Paint Mark:**

- The accelerator pedal requires modification. Make sure to perform the modification process during the Work Procedure.

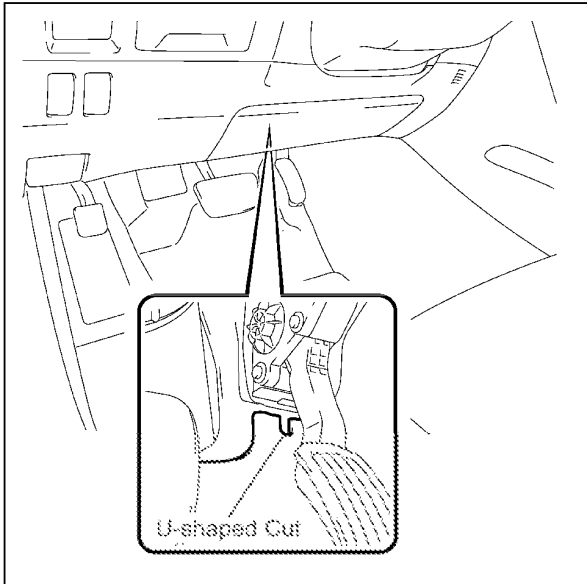

**2. INSPECT THE FLOOR CARPET**

- a) Verify if the floor carpet has a “U” shaped cut in the location shown.

**With “U” Shaped Cut:**

- The floor carpet remedy has been applied by the factory, **NO** modification is required.

**NO “U” Shaped Cut:**

- The floor carpet requires modification. Make sure to perform the modification process during the Work Procedure.

ECM CID		
AZ/AR Engine	Current CID	New CID
2010 Model Year AR AT/ULEV	333B5000	333B5100
2010 Model Year AR MT/ULEV	30669000	30669100
2010 Model Year AR AT/PZEV	333B6000	333B6100
GR Engine	Current CID	New CID
2010 Model Year GR	333B8000	333B8100

**3. INSPECT THE ECM CALIBRATION ID (CID)**

- a) Verify if the ECM has the **NEW** CID.

**With NEW ECM CID:**

- The ECM CID has been applied by the factory, **NO** modification is required.
- Confirm the vehicle has the correct floor mat following the instructions on page 18.

**With Current ECM CID:**

- The ECM CID requires updating. Make sure to perform the updating process during the Work Procedure.



## C. REMOVE THE ACCELERATOR PEDAL



### ACCELERATOR PEDAL HANDLING NOTES:

- DO NOT drop
- DO NOT reuse an accelerator pedal that has been dropped
- Avoid vibration and shock
- DO NOT place the sensor portion of the pedal in a vise
- Cover and uncover the sensor while in the vehicle to prevent damage and debris from entering

[CLICK HERE TO WATCH THE VIDEO BEFORE BEGINNING THE WORK PROCEDURE](#)

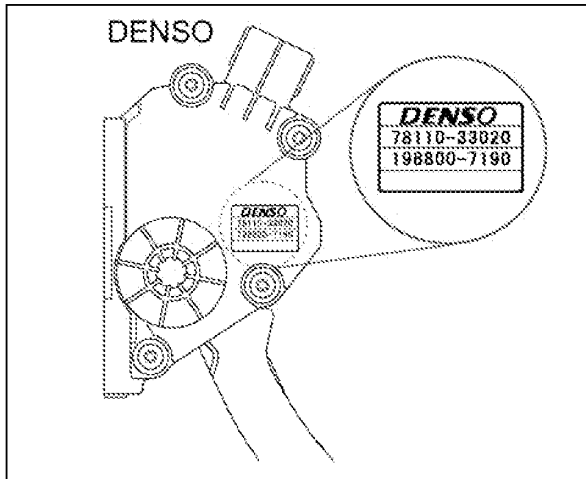

### 4. IDENTIFY AND REMOVE THE DENSO ACCELERATOR PEDAL ASSEMBLY

[Click here to watch the video to supplement this step.](#)

- Verify the vehicle has a Denso accelerator pedal assembly by identifying the manufacturing imprint as illustrated here.
- If the pedal is manufactured by Denso continue following the instructions.
- If the pedal is manufactured by CTS, DO NOT CONTINUE WITH THESE INSTRUCTIONS.

#### NOTE

**Modifications should only be performed on Denso pedals.**

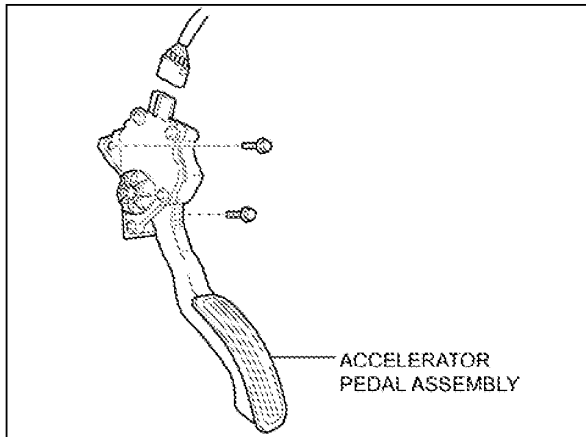

- Disconnect the accelerator pedal electrical connector.
- Remove the 2 bolts.

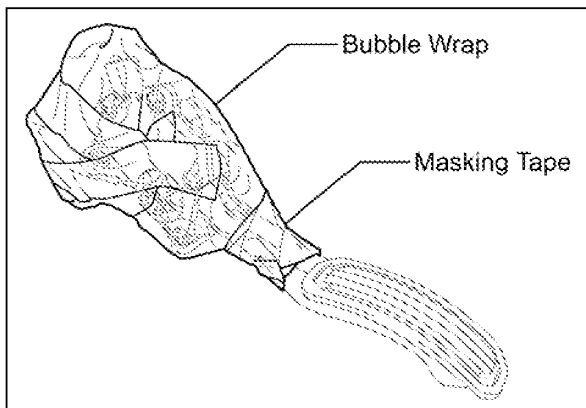

- While still inside the vehicle, use bubble wrap and masking tape to cover and protect the sensor.

#### NOTE:

- Be sure to use bubble wrap to protect the sensor.
- Be sure to seal the bubble wrap with masking tape to prevent damage to the sensor, and cutting debris from entering the pedal's movable lock.
- DO NOT reuse the bubble wrap.

## D. CUT THE DENSO ACCELERATOR PEDAL

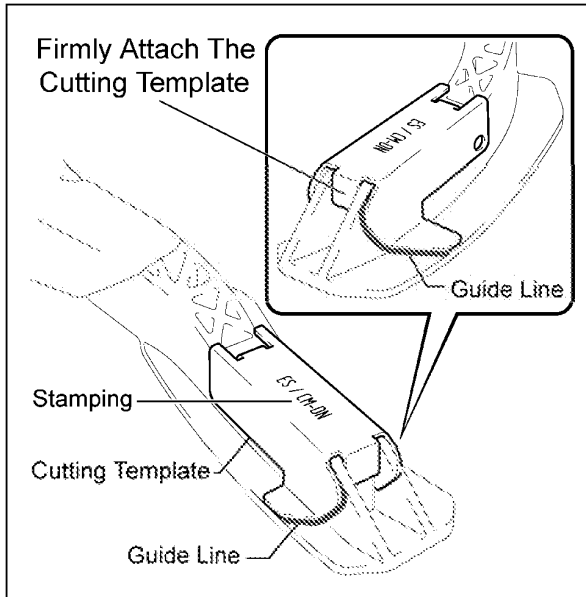

### 5. MARK THE AREA TO BE CUT

[Click here to watch the video to supplement steps \(5-6\).](#)

- Firmly set the template to the pedal. Scribe guide lines to outline the area to be cut.

Cutting Template:

- Color: Silver
- Stamping: ES / CM-DN

#### NOTE:

- DO NOT mark the area beyond the template.
- Use a flat tip screwdriver if a scribe is not available.
- Make sure to use the correct cutting template by verifying the color and stamping.
- Never cut or sand the pedal while the template is on the pedal.

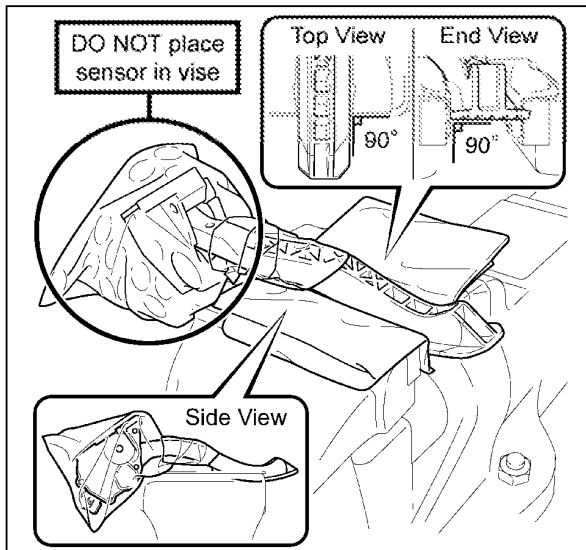

### 6. SECURE THE ACCELERATOR PEDAL ASSEMBLY

- Set the pedal in the vise at a right angle using a shop cloth while avoiding the sensor portion.

#### NOTE:

- DO NOT place the sensor in the vise to avoid damage.
- Firmly secure the pedal to prevent it from moving.
- DO NOT over tighten the vise.

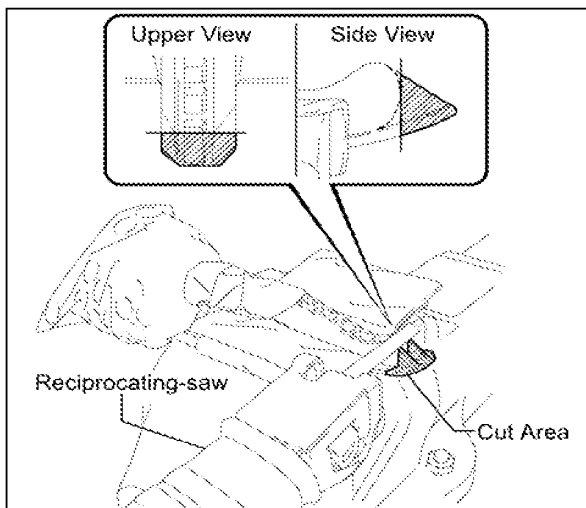

### 7. CUT THE ACCELERATOR PEDAL

[Click here to watch the video to supplement steps \(7-10\).](#)

- Using a reciprocating saw, cut the lower section of the pedal.

#### NOTE:

- Always wear protective eyewear, gloves, and dust mask when cutting.
- The cut must be straight and clean.
- Apply consistent pressure during cutting.
- Do not stop while cutting.

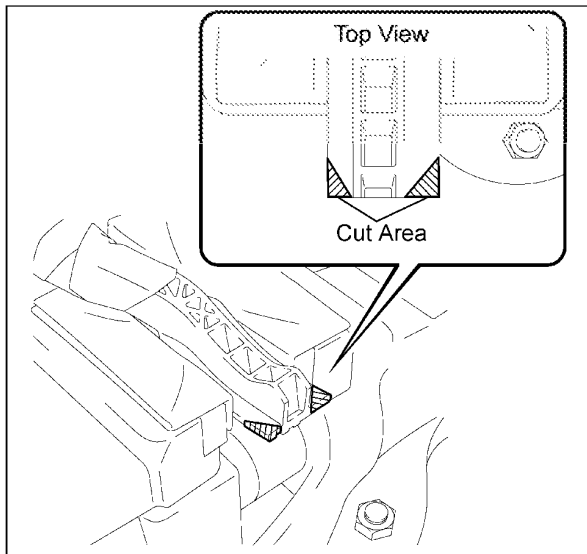

b) Using a reciprocating saw, cut the corners of the pedal.

**NOTE:**

- Always wear protective eyewear, gloves, and dust mask when cutting.
- Each cut must be straight and clean.
- Apply consistent pressure during cutting.
- Do not stop while cutting.

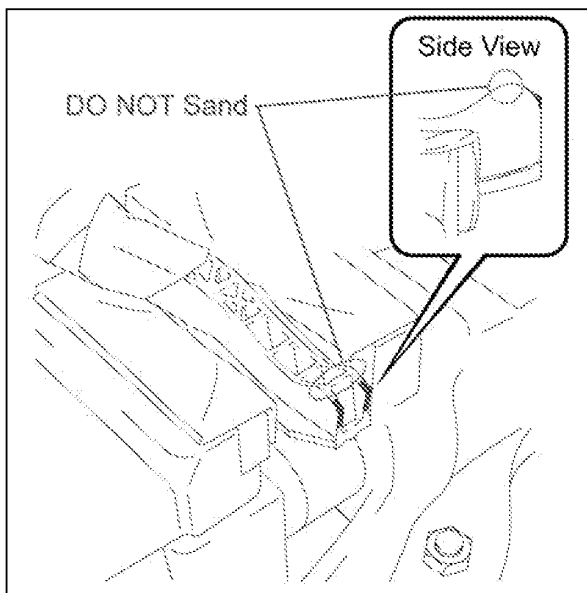

**8. SAND THE RADIUS LINE**

a) Using an orbital sander, sand the radius line which was scribed and remove the sharp edges and burrs.

**NOTE:**

- Always wear protective eyewear, gloves, and dust mask when sanding.
- DO NOT sand the back of the pedal arm.

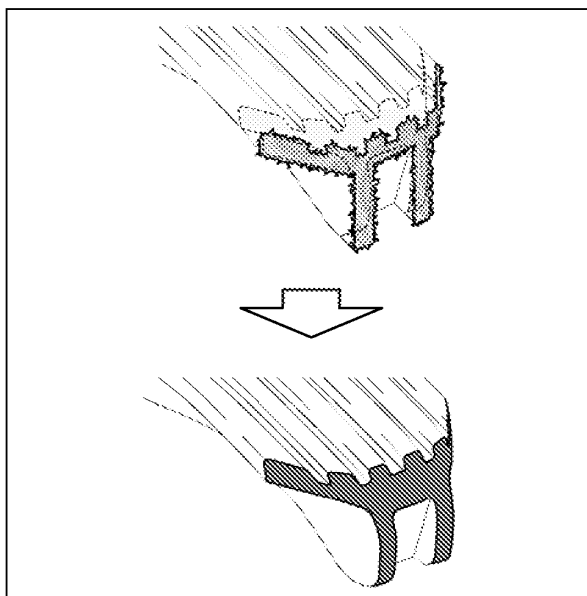

**9. REMOVE ALL BURRS FROM THE CUTTING SURFACE**

- a) Remove the pedal from the vise.
- b) Turn the pedal over and set the pedal in the vise using a shop cloth while avoiding the sensor.
- c) Using an orbital sander and file, remove all burrs from the cutting surface. The cut edges along the foot pad should be rounded and not square.
- d) Finish the cut surface and all edges with 400 grit sandpaper.

**NOTE:**

- Always wear protective eyewear, gloves, and dust mask when sanding or filing.
- DO NOT place the sensor in the vise to avoid damage.
- Firmly secure the pedal to prevent it from moving.
- DO NOT over tighten the vise.

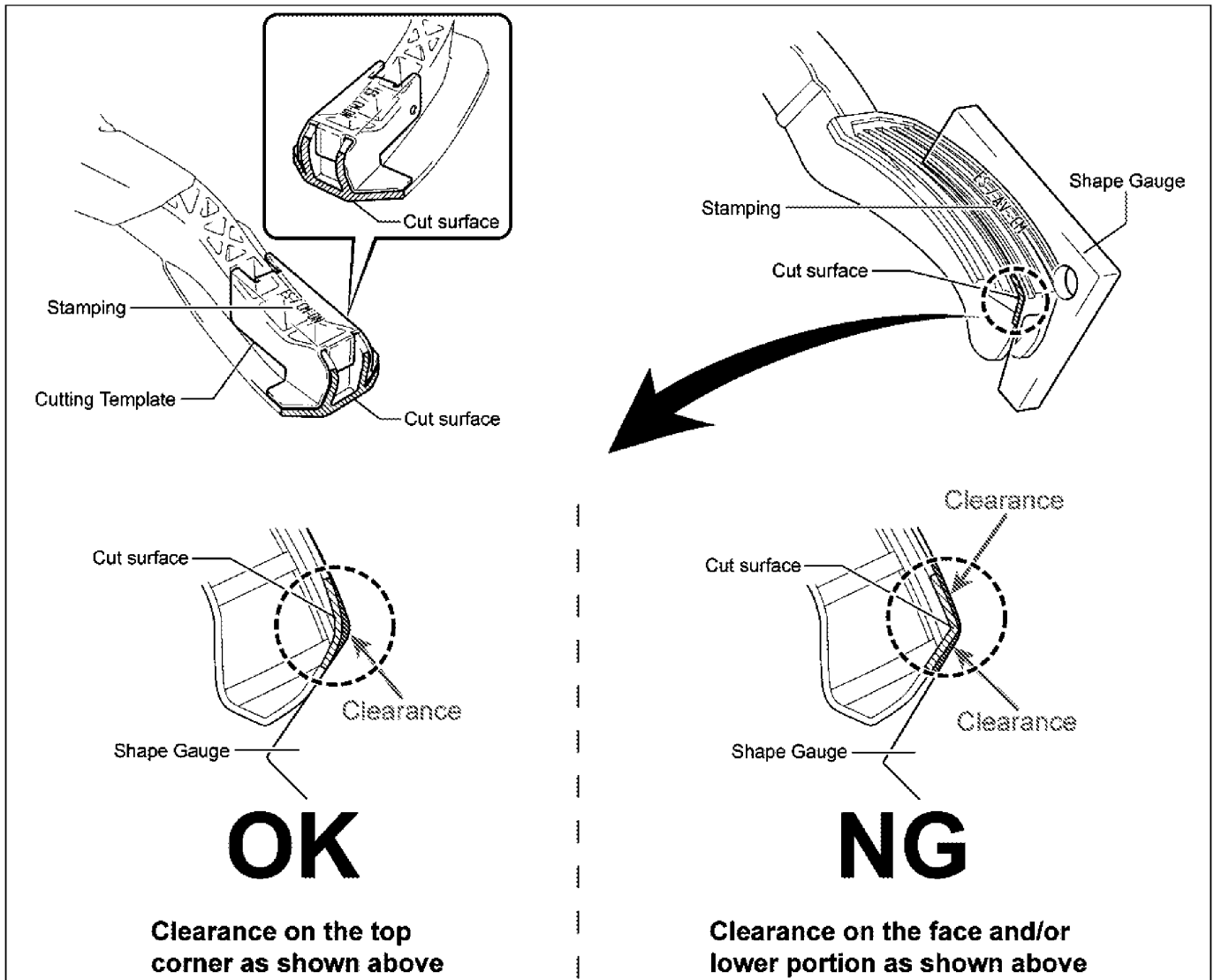

## 10. CHECK THE SHAPE OF THE PEDAL

- a) Using the correct cutting template and shape gauge, check the shape of the pedal.

### Cutting Template

Color: Silver,  
Stamping: ES / CM-DN

### Shape Gauge

Color: Silver  
Stamping: ES / AV-CM

- b) If the shape does NOT match the template and or gauge, continue filing.  
c) If the shape matches the template and gauge, touch the cut surface with your hand to verify it is smooth and free of burrs.

### NOTE:

- Always wear protective eyewear, gloves, and dust mask when sanding or filing.
- A tolerance of -1.0 mm is permissible between the final cut surface and the template.

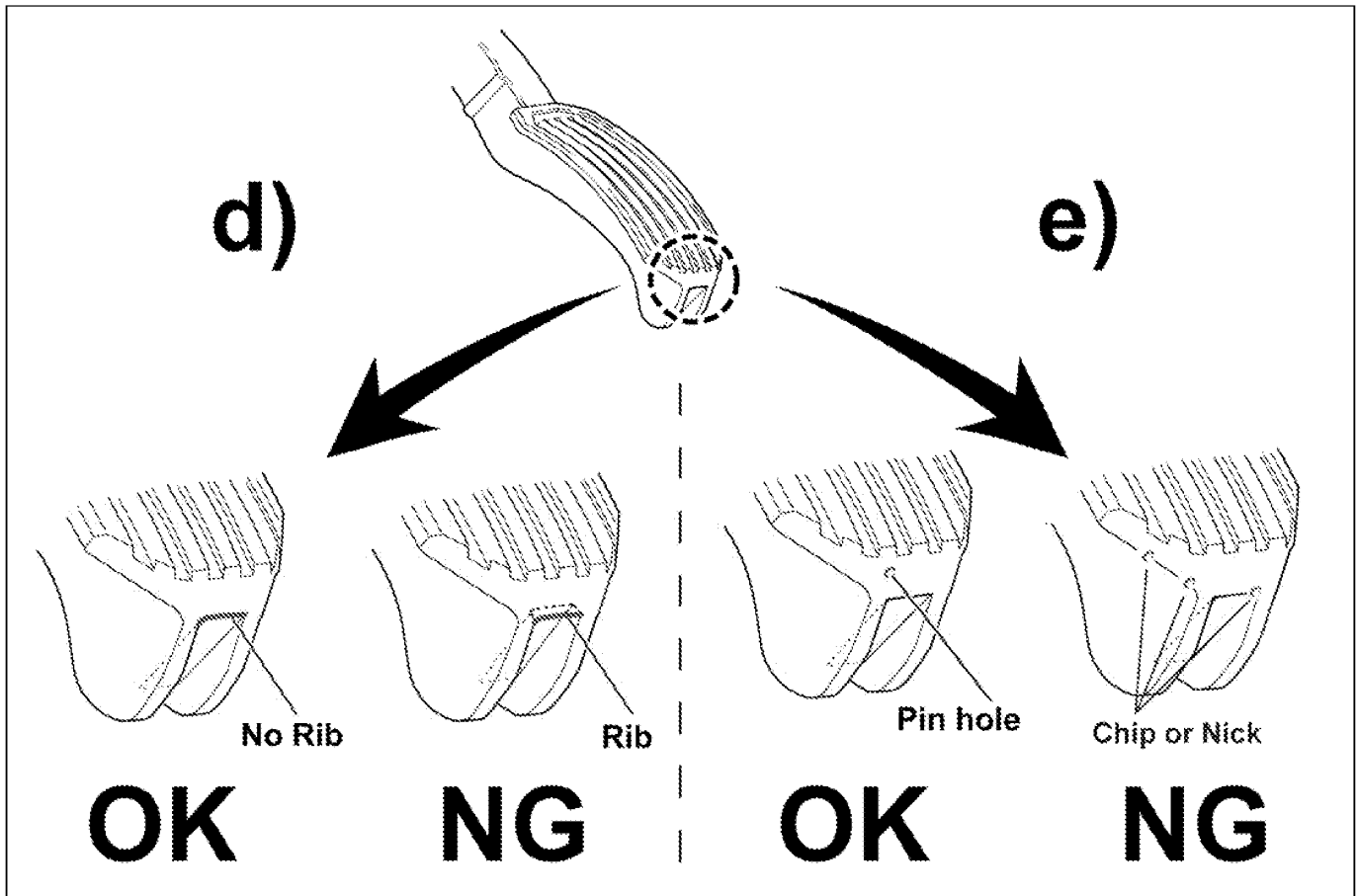

- d) Check for a rib as shown. If there is a rib, file it until it is gone.
- e) Check for any chips or nicks on the finished surface edge. If there are any chips or nicks, file the edge to make them smooth.
- f) DENSO accelerator pedal modification is now complete.

**NOTE:**

The key point of judgment is a "smooth pedal surface".

## E. FLOOR CARPET MODIFICATION

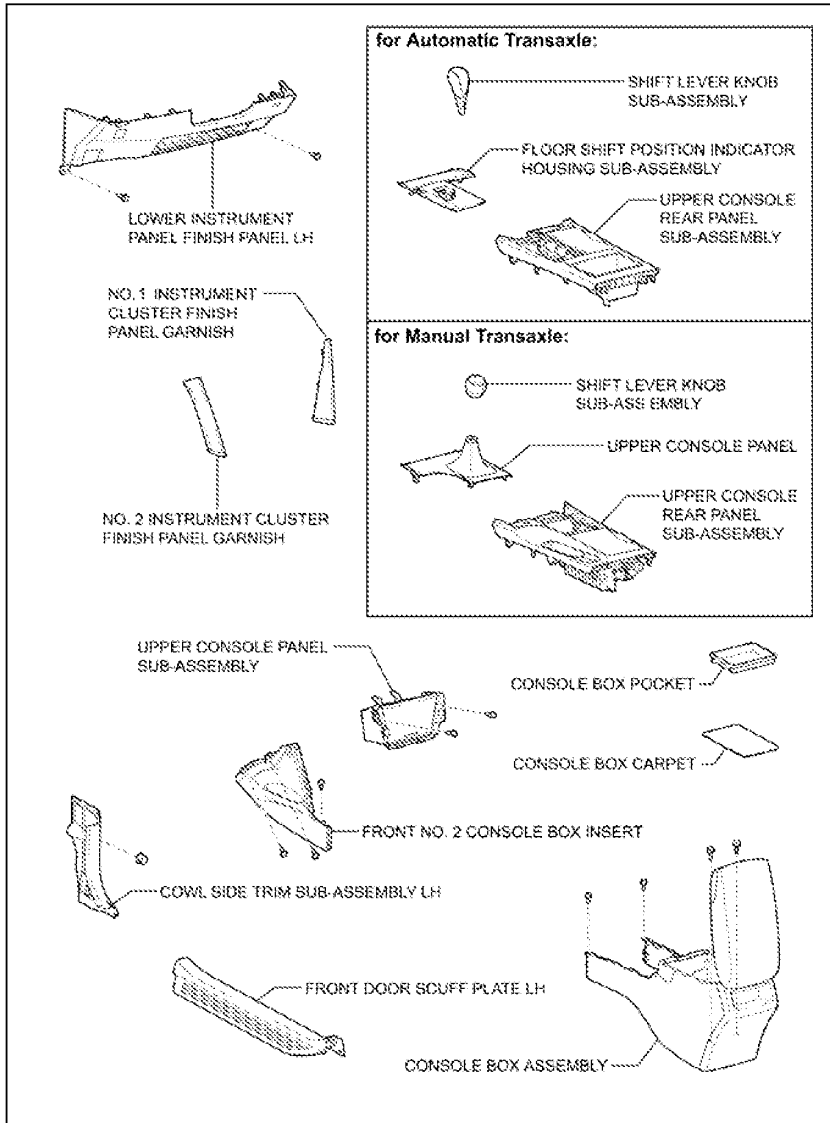

### 1. REMOVE THE FOLLOWING COMPONENTS

Click here to watch the video to supplement steps (1-6).

- Front door scuff plate LH
- Cowl side trim sub-assembly LH
- Lower instrument panel finish panel LH
- Shift lever knob sub-assembly
- No. 1 instrument cluster finish panel garnish
- No. 2 instrument cluster finish panel garnish
- Floor shift position indicator housing sub-assembly **(automatic transmission ONLY)**
- Upper console panel **(manual transmission ONLY)**
- Upper console rear panel sub-assembly
- Upper console panel sub-assembly
- Console box pocket
- Console box carpet
- Console box assembly
- Front No. 2 console box insert

#### NOTE

For additional information on removal of the components above, please refer to TIS.

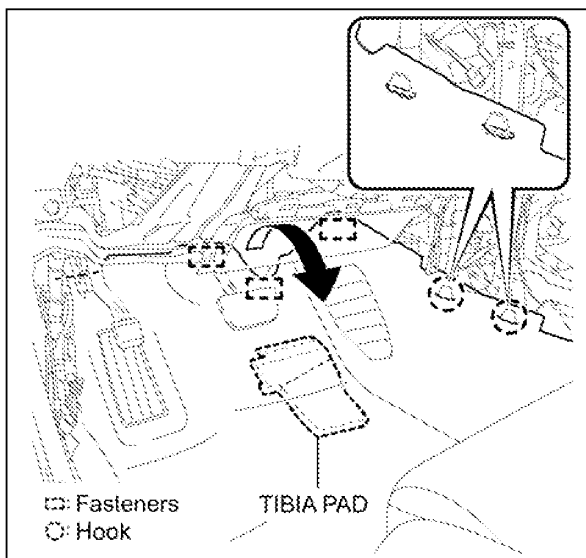

### 2. PULL BACK THE FLOOR CARPET

- Disengage the 3 fasteners.
- Disengage the floor carpet from the 2 hooks and pull it back as illustrated.

#### NOTE:

There are some vehicles with a hole, two holes or no hole in the floor carpet for a hook.

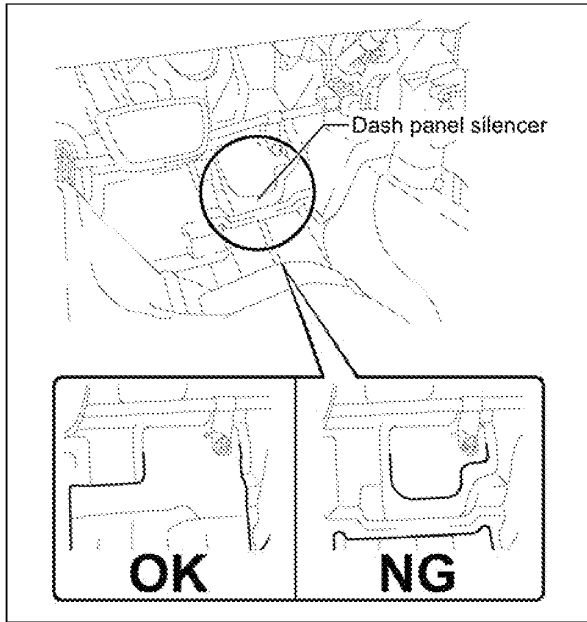

### 3. INSPECT THE LOWER PORTION OF THE FABRIC FLOOR SILENCING MATERIAL

- a) Inspect the lower portion of the fabric floor silencing material.
  - If OK, proceed to step 4 "RUBBER PAD APPLICATION" below.
  - If NG, please refer to APPENDIX "B" for "CUT THE FLOOR SILENCING MATERIAL"

**NOTE:**

The fabric floor silencing material is a soft, gray, paper-like material beneath the carpet.

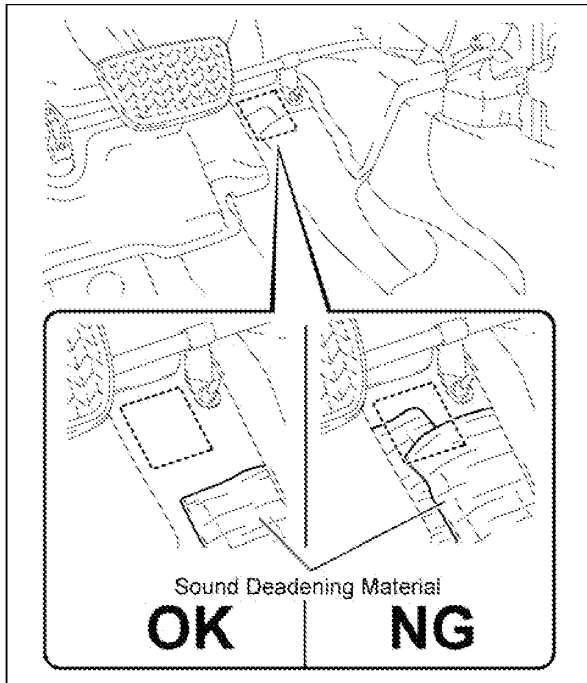

### 4. RUBBER PAD APPLICATION

- a) Inspect the rubber pad application area for sound deadening material.
  - If OK (no sound deadening material in pad application area), proceed to step "b" below.
  - If NG (sound deadening material found in application area), please refer to APPENDIX "C" for "REMOVE THE SOUND DEADENING MATERIAL".

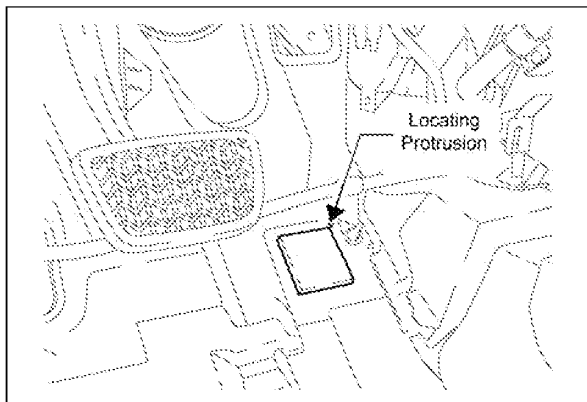

- b) Clean and degrease the rubber pad application area.
- c) Peel the double sided tape cover off the **NEW** rubber pad.
- d) Apply the rubber pad to the floor pan. The upper right corner of the rubber pad needs to be positioned next to the locating protrusion.

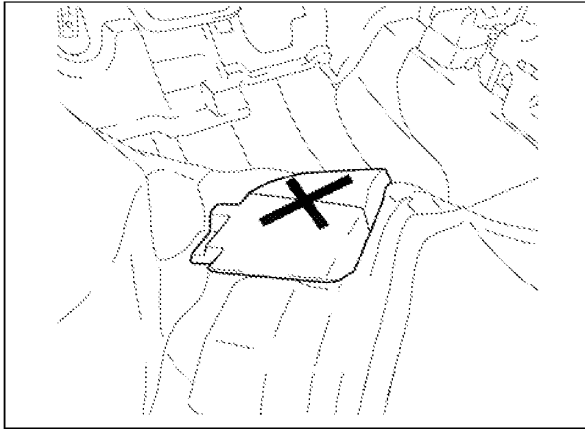

## 5. REMOVE THE TIBIA PADS

- a) Place an "X" mark on the tibia pads before removing. This will prevent them from being mixed up with the new pads.
- b) Using a hair dryer or a low temperature heat gun, warm up the carpet side of the 2 tibia pads until the adhesive is loose. This will make it easier to remove the 2 tibia pads from the carpet. Pay close attention when using the hair dryer or low temperature heat gun to prevent damage to the carpet.
- c) Remove the tibia pads. CAUTION: DO NOT forcefully pull the pads. Doing so may damage the carpet. If necessary, re-heat the carpet to make the adhesive more pliable.



Carefully take the time to understand Step 6 (Next step). It is necessary to correctly complete this procedure to prevent the tibia pads from slipping.

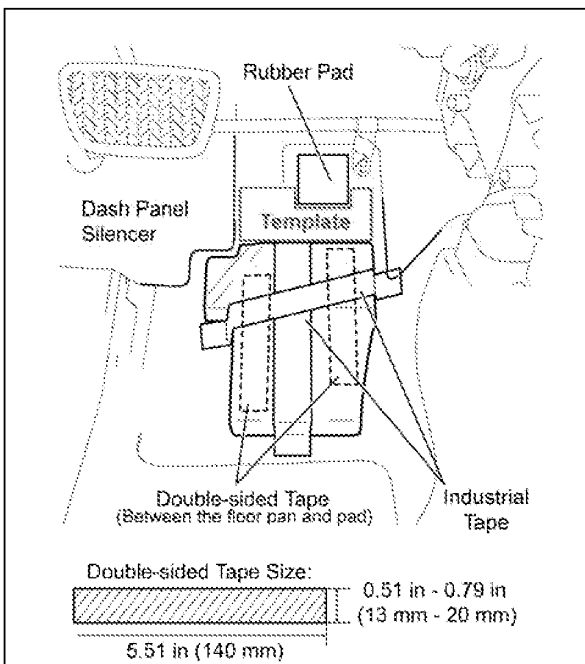

## 6. INSTALL THE NEW TIBIA PAD

- a) Apply double sided tape to the bottom (floor pan side) of the tibia pad.
- b) Using the Tibia Pad Placement Template as a guide (Template is located in the Appendix), position and apply the **NEW** Tibia pad to the floor pan.
- c) Remove template.
- d) Apply a piece of industrial adhesive tape from the top to the bottom of the tibia pad.
- e) Apply a second piece of industrial adhesive tape from the left to the right side of the tibia pad.

### NOTE:

- Both pieces of industrial adhesive tape should have a good contact surface to the floor pan.
- Angle the industrial adhesive tape running left to right to ensure that both tibia pads are covered.

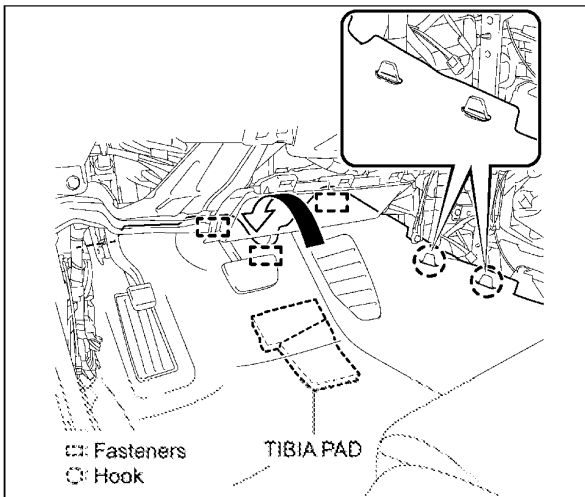

- e) Place the floor carpet back into position and engage the 2 hooks as shown in the illustration.
- f) Engage the 3 fasteners.

### NOTE:

- Be careful not to detach the tibia pads when placing the carpet back into position.
- There are some vehicles with a hole, two holes or no hole in the floor carpet for a hook. For the vehicles with a hole(s), please be certain to install the hook to the hole(s). If the vehicle has no hole in the floor carpet for a hook, please reset the floor carpet to the original position.



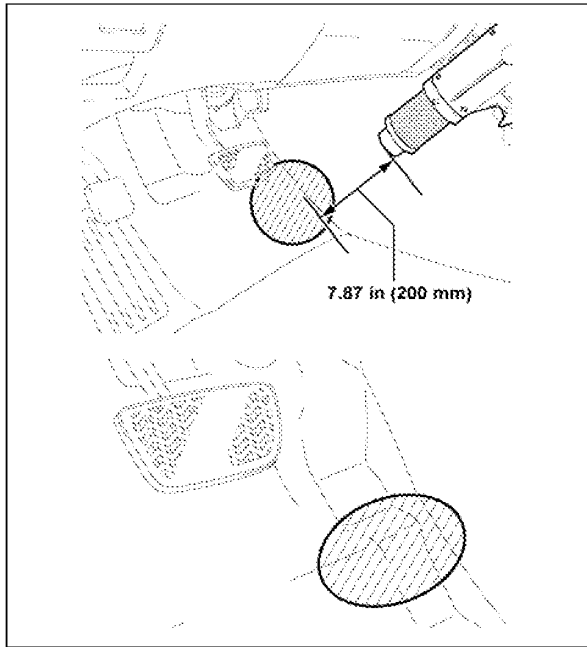

- g) Heat the floor carpet area for 2 minutes as shown and smooth it out by pushing it with your hand. Heat the same area again for another minute, and smooth the carpet firmly.

**NOTE:**

- Always wear protective gloves when heating the floor carpet.
- Keep the hair dryer/ low temperature heat gun more than 8 inches (20 cm) away from the floor carpet, and stop after 1 or 2 minute intervals. Continuous heating of the floor carpet may cause damage.
- DO NOT leave hair drier or low temperature heat gun inside the vehicle when it is hot, to prevent unintended heat damage to interior parts.

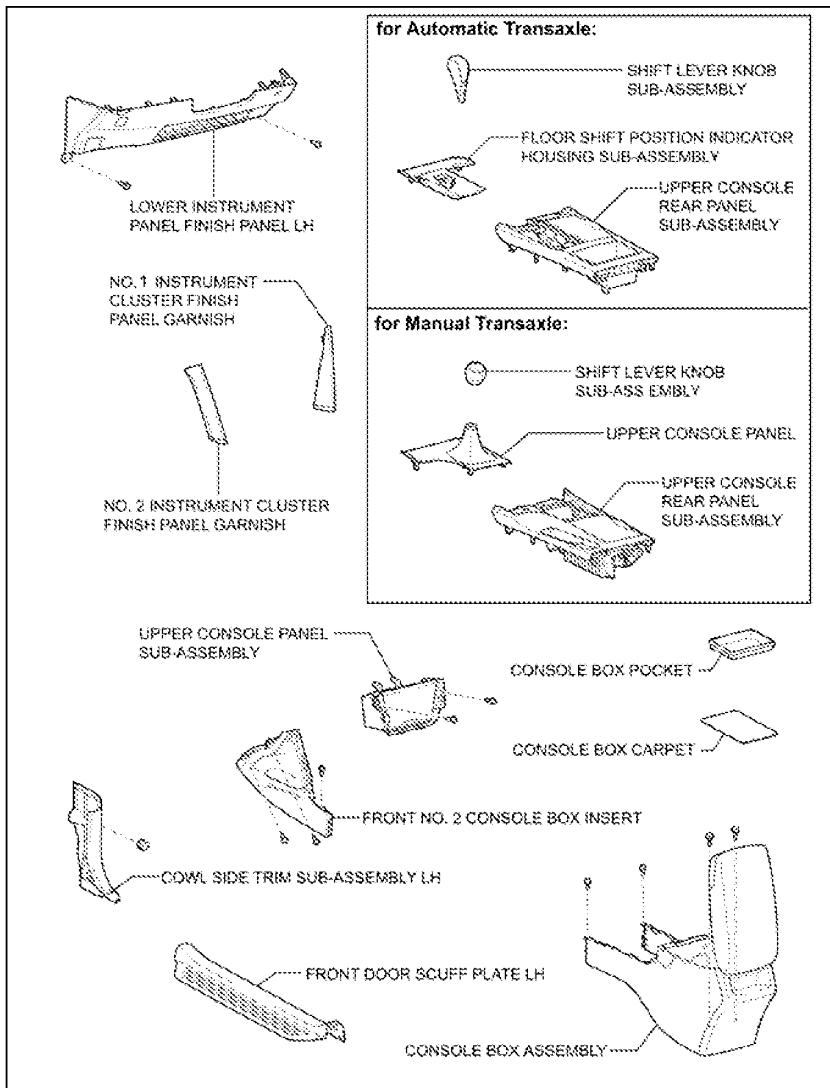

**7. REINSTALL THE FOLLOWING COMPONENTS**

- Front No. 2 console box insert
- Console box assembly
- Console box carpet
- Console box pocket
- Upper console panel sub-assembly
- Upper console rear panel sub-assembly
- Upper console panel (*manual transmission ONLY*)
- Floor shift position indicator housing sub-assembly (*automatic transmission ONLY*)
- No. 2 instrument cluster finish panel garnish
- No. 1 instrument cluster finish panel garnish
- Shift lever knob sub-assembly
- Lower instrument panel finish panel LH
- Cowl side trim sub-assembly LH
- Front door scuff plate LH

**NOTE**

For additional information on installation of the components above, please refer to TIS.

## F. REINSTALL THE ACCELERATOR PEDAL ASSEMBLY



Ensure the correct pedal and bolts are being reinstalled in the vehicle from which it was removed.

### 1. REINSTALL THE ACCELERATOR PEDAL ASSEMBLY

[Click here to watch the video to supplement steps \(1-8\).](#)

- Remove and discard the masking tape and bubble wrap from the accelerator pedal assembly, while it is inside the vehicle.
- Reinstall the pedal with the 2 bolts and torque to specification.

**Torque Specification:**  
**5.4 Nm (55 kgf cm, 48 in. lbf)**

- Reconnect the accelerator pedal connector.

#### NOTE

- DO NOT reuse the bubble wrap.
- For additional information on accelerator pedal installation, please refer to TIS.

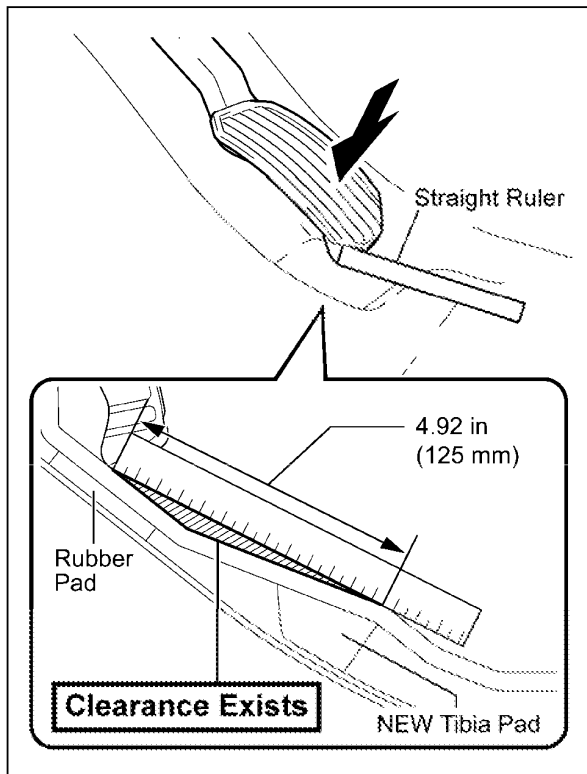

### 2. INSPECT THE FLOOR CARPET

- With the accelerator pedal fully depressed, confirm clearance exists between the floor carpet and the straight ruler as shown.
- If no clearance exists, reshape the carpet again.
- Confirm the claw and all fasteners of the floor carpet are securely attached.

### 3. INSPECT ACCELERATOR PEDAL OPERATION

- a) Inspect the carpet and floor mat and clean them as appropriate.
- b) Confirm the correct floor mat for this model is secured with the retaining hooks (clips).
  - If the grommets in the floor for the vehicle are in poor condition, refer to the appropriate TSB and repair the grommets.

**NOTE:**

- If a Recalled All Weather Floor Mat (AWFM) has been identified, remove the AWFM from the vehicle and **CUT THE RECALLED AWFM SO THAT IT CANNOT BE REUSED.**
- **You may remove the semi-permanent installation plastic straps for the carpeted floor mat once the repair is completed.**

Locate the ten digit floor mat part number on the bottom of the back side of the mat as illustrated below. PLEASE NOTE, the floor mat part numbers are 12 digits but only the first ten are shown.

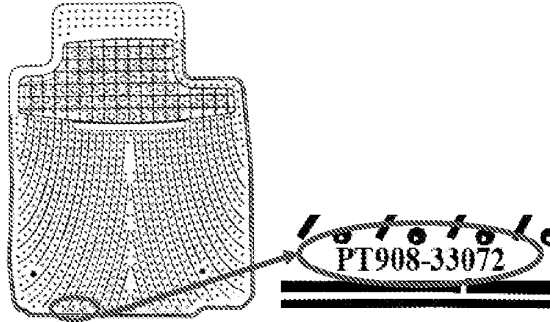

**For Carpeted Floor Mats:**

Utilizing the ten digit part number and the chart below, confirm the vehicle has the correct carpeted floor mat.

Part Number	Model	Type	07	08	09	10	Color
PT206-32060-11	Camry / Camry Hybrid	Carpeted	x	x	x	x	Ash
PT206-32060-12	Camry / Camry Hybrid	Carpeted	x	x	x	x	Dk Charcoal
PT206-32060-14	Camry / Camry Hybrid	Carpeted	x	x	x	x	Bisque
PT206-32078-40	Camry Hybrid	Carpeted	x				Bisque
PT206-32100-12	Camry / Camry Hybrid	Carpeted				x	Gray
PT206-32100-45	Camry / Camry Hybrid	Carpeted				x	Brown

**For All Weather Floor Mats (AWFM):**

Utilizing the ten digit part number and the chart below, confirm the vehicle has the newly designed AWFM.

Part Number	Model	Type	07	08	09	10	Color
PT908-0310W-02	Camry	All Weather	x	x	x	x	Black
PT908-0310W-14	Camry	All Weather	x	x	x	x	Brown

**NOTE:**

The part numbers listed above are for the 2 piece (driver & front passenger) campaign set ONLY.

**DO NOT** use the recalled AWFM listed below. These AWFM must be removed from the vehicle and recovered by the dealer.

Part Number	Model	Type	07	08	09	10	Color
PT908-03071-02	Camry - Do not use	All Weather	x	x	x	x	Black
PT908-03071-14	Camry - Do not use	All Weather	x	x	x	x	Brown
PT908-0307F-02	Camry - Do not use	All Weather	x	x			Black
PT908-0307F-14	Camry - Do not use	All Weather	x	x			Brown
PT908-32070-02	Camry - Do not use	All Weather	x				Black
PT908-32070-14	Camry - Do not use	All Weather	x				Brown

All recalled AWFM will be placed on Warranty Parts Recovery, and dealers will be required to return them to TMS. AWFM that are not returned will result in the claim being debited.

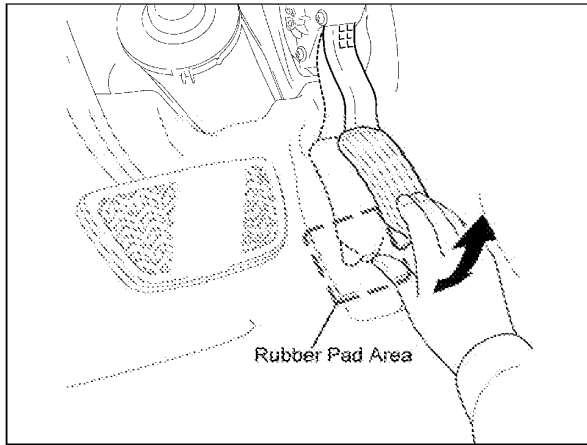

- c) Confirm the pedal does not get caught on the floor or floor mat during operation.
- d) Confirm the pedal operates properly.
- e) Confirm that the bottom of the pedal contacts the rubber pad area when the accelerator pedal is fully depressed.

#### 4. INSPECT THE ACCELERATOR PEDAL ASSEMBLY OPERATION

- a) Connect Techstream to the DLC3.
- b) Enter the following menus: Powertrain / Engine and ECT / Data List.
- c) Check the values by referring to the table below.

Tester Display	Measurement:	Normal Condition
Accel Sens. No.1 Volt %	Accelerator pedal position sensor No. 1	Accelerator Pedal Released: 10% - 25%
		Accelerator Pedal Fully Depressed: 60% - 90%
Accel Sens. No.2 Volt %	Accelerator pedal position sensor No. 2	Accelerator Pedal Released: 20% - 45%
		Accelerator Pedal Fully Depressed: 80% - 100%

AZ/AR Engine	Current CID	New CID
2007-2009 Model Year AZ AT/PZEV	333A7200	333A7300
	333A7100	
	333A7000	
	33368100	
	33368000	
2007-2009 Model Year AZ AT/ULEV	333A5200	333A5300
	333A5100	
	333A5000	
	33366100	
	33366000	
2007-2009 MY AZ MT/ULEV	333A6100	333A6200
	333A6000	
	33367000	
2010 Model Year AR AT/PZEV	333B6000	333B6100
2010 Model Year AR AT/ULEV	333B5000	333B5100
2010 Model Year AR MT/ULEV	30669000	30669100

#### 5. REFLASH THE ECM

- a) Reflash the ECM with the **NEW** Override System software following TSIB SS002-07.
- b) For Calibration ID, please refer to the table on the left.

**NOTE:**  
ECM reflashing on the Camry HV is NOT required. The Camry HV has a motor protection feature that operates in the same manner as the Override System software.

GR Engine	Current CID	New CID
2007 Model Year GR	33334100	33334200
	33334000	
2008-2009 Model Year GR	333A8100	333A8200
	333A8000	
2010 Model Year GR	333B8000	333B8100



- b) Log in to TIS.
- c) Input Vehicle Mileage and Repair Order number.
- d) Check the "Performed" radio button for the 90L campaign and any other campaigns completed during this service event.
- e) Select the Report button.

**Diagnostic Report**

---

**Vehicle Information**

Mileage: 7787

Repair Order: 77888

Our systems show the following campaigns are outstanding. Have any of these campaigns been completed? (Check for SSC door label if unsure.)

90L  Performed  Not Performed

- a) Confirm Customer Health Check Report information is correct.

**Diagnostic Report**

---

**Vehicle Information**

Vehicle: 2007 Camry      VIN: 4T1BE46K07A      Mileage: 7787

Repair Order: 77888

---

**Health Check Summary**

Checkpoints	Status	Comments
Powertrain Systems	All systems OK	
Chassis Systems	All systems OK	
Electrical Systems	All systems OK	
Network Systems	All systems OK	
Service Campaigns	No Action Required	90L Performed

Performed 12/21/05 3:48 PM

- b) Print Customer Health Check Report from TIS.
- c) Sign and provide to the customer.

8. TEST DRIVE THE VEHICLE AND INSPECT FOR ANY PROBLEMS

9. AFFIX THE AUTHORIZED MODIFICATIONS LABEL

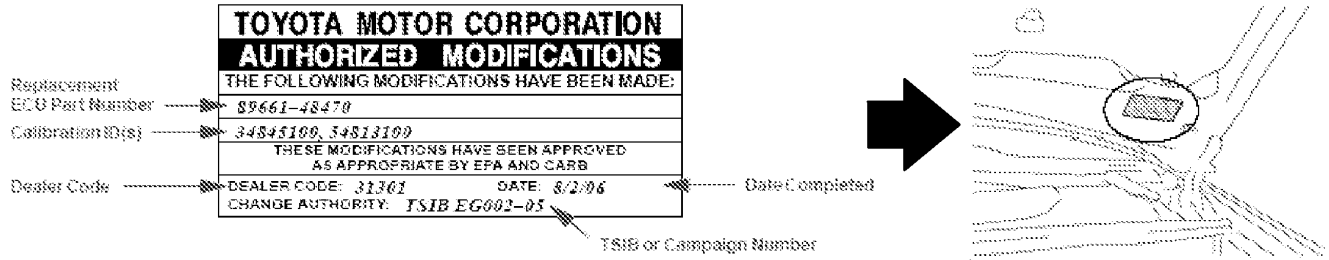

a) Using a permanent marker or ball point pen, complete the Authorized Modifications Label and attach it to the underside of the hood in front of the driver as shown.

- Replacement ECM Part Number & Calibration ID(s)

AR/AZ Engine	WMI	Replacement ECU Part Number	New Calibration ID
2007-2009 Model Year - AZ AT/PZEV	4T1	89661-06G43	333A7300
	JTN	89661-33E53	
2007-2009 Model Year - AZ AT/ULEV	4T1	89661-06G13	333A5300
	JTN	89661-33E33	
2007-2009 Model Year - AZ MT/ULEV	4T1	89661-06G22	333A6200
	JTN	89661-33E42	
2010 Model Year - AR AT/PZEV	4T1	89661-06J41	333B6100
	JTN	89661-33F01	
2010 Model Year - AR AT/ULEV	4T1	89661-06J11	333B5100
	JTN	89661-33E91	
2010 Model Year - AR MT/ULEV	4T1	89661-06J21	30669100

GR Engine	WMI	Replacement ECU Part Number	New Calibration ID
2007 Model Year GR	4T1	89661-06C22	33334200
	JTN	89661-33772	
2008-2009 Model Year GR	4T1	89661-06G52	333A8200
	JTN	89661-33E62	
2010 Model Year GR	4T1	89661-06J51	333B8100
	JTN	89661-33F21	

- Dealer Code
- Date Completed
- Campaign Number

NOTE:

Authorized Modifications Label (in packages of 25) can be ordered through the Material Distribution Center (MDC), P/N 00451-00001-LBL.

VI. APPENDIX

A. RECALLED PARTS DISPOSAL

As required by Federal Regulations, please make sure all recalled parts (original parts) removed from the vehicle are disposed of in a manner in which they will not be reused, **unless requested for parts recovery return.**

## B. CUT THE FABRIC FLOOR SILENCING MATERIAL

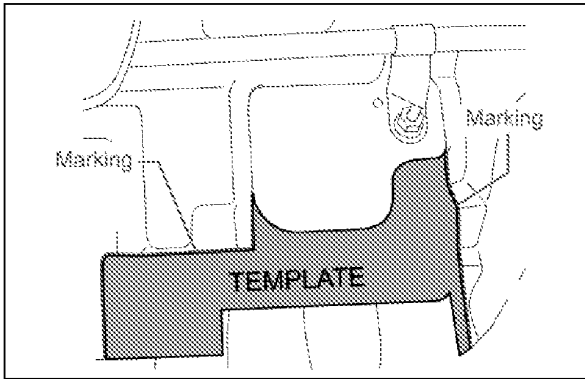

- a) Photocopy and cut out the template located at the end of the appendix.

- b) Hold the template against the fabric floor silencing material and mark the template outline with a pen.

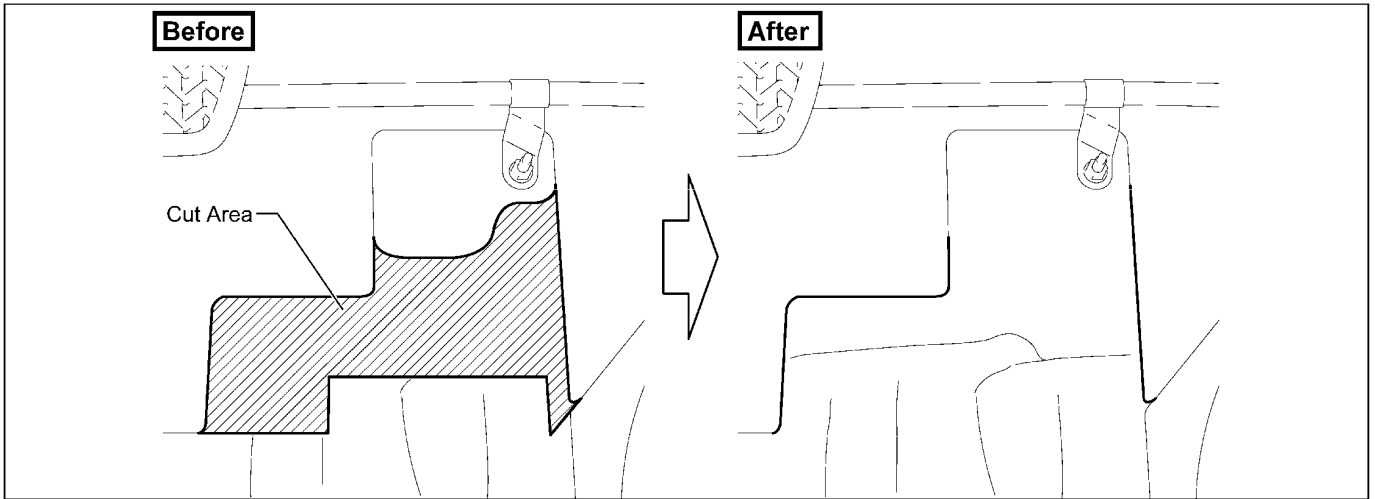

## C. REMOVE THE SOUND DEADENING MATERIAL

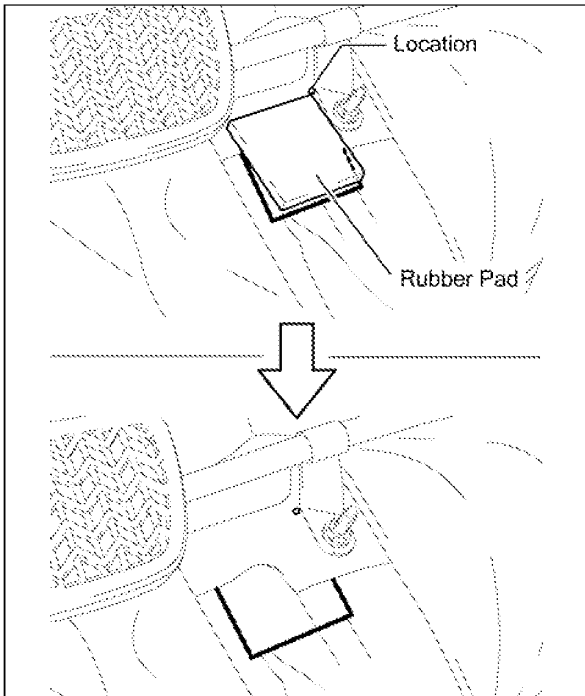

1. Temporarily place the rubber pad on the floor panel as shown, and outline the pad on the sound deadening material with a ball point pen.



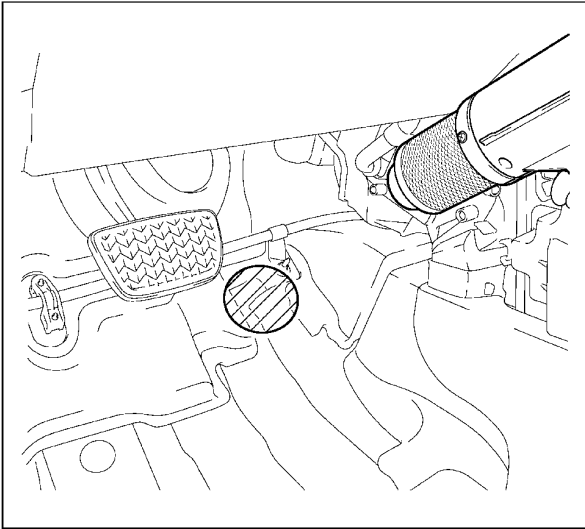

2. Using a hair dryer or low temperature heat gun, warm up the sound deadening material until it becomes soft.

**NOTE:**

- Make sure not to damage the fabric floor silencing material.
- Pay close attention when using the hair dryer or low temperature heat gun to prevent damage to the carpet.

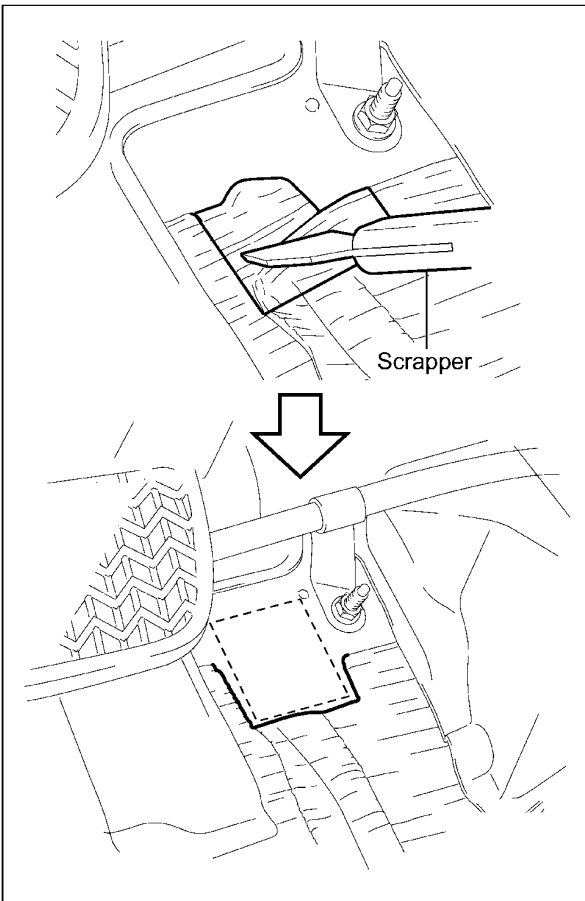

3. Using a scraper, remove the sound deadening material from the rubber pad application area.
4. Remove any loose sound deadening material from the rubber pad application area.

**NOTE:**

- Wear protective gloves during the scraping process.
- Warm up the sound deadening material again, if it becomes hard during removal.
- Remove the sound deadening material until the rubber pad application surface is smooth.
- Make sure not to damage the paint film on the floor panel when scraping.
- Apply touch up paint if the paint film was damaged.

# Floor Silencing Material Template

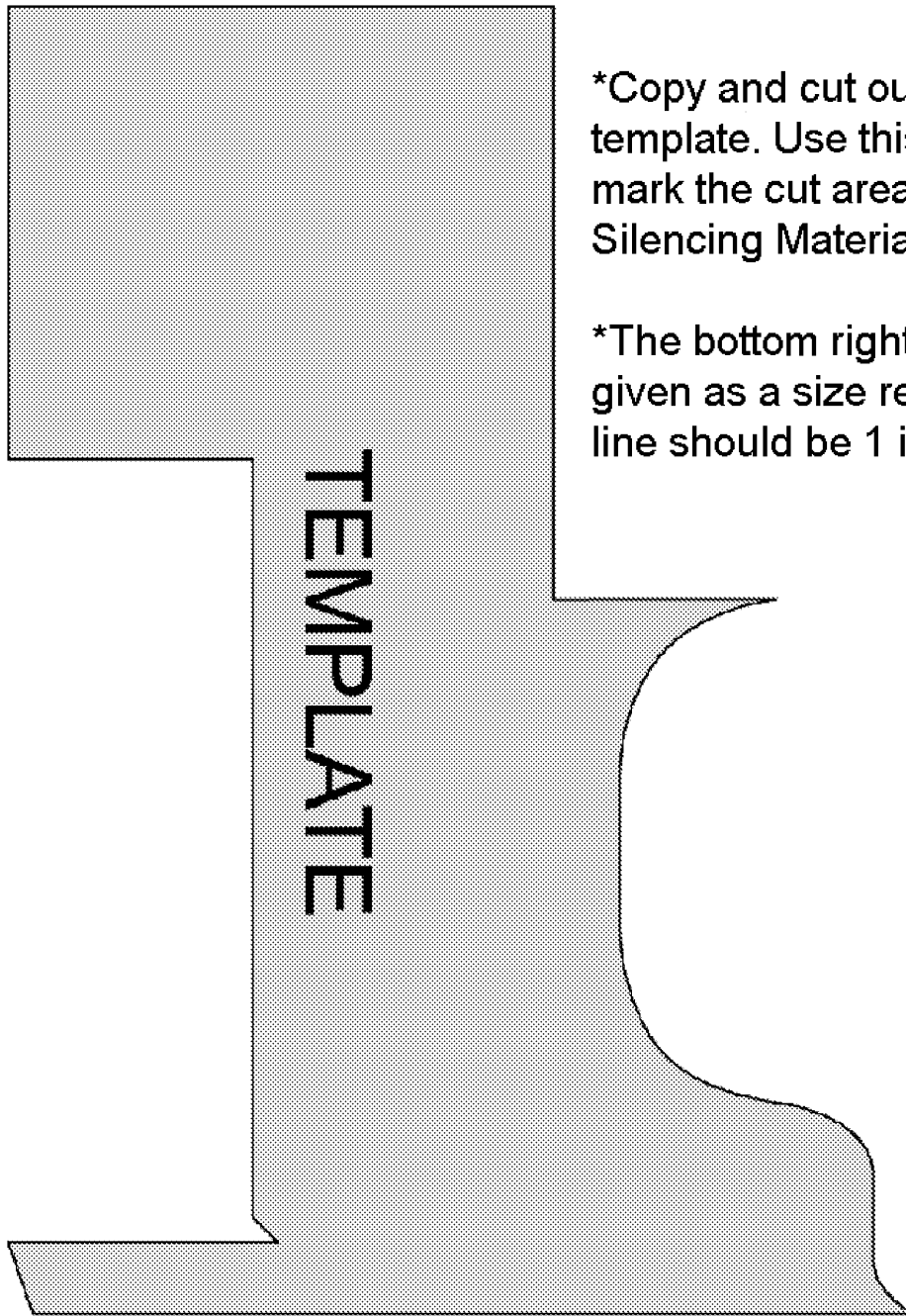

\*Copy and cut out this template. Use this template to mark the cut area on the Floor Silencing Material.

\*The bottom right guide line is given as a size reference. This line should be 1 inch in size.

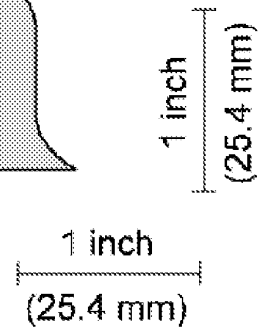

# Tibia Pad Placement Template

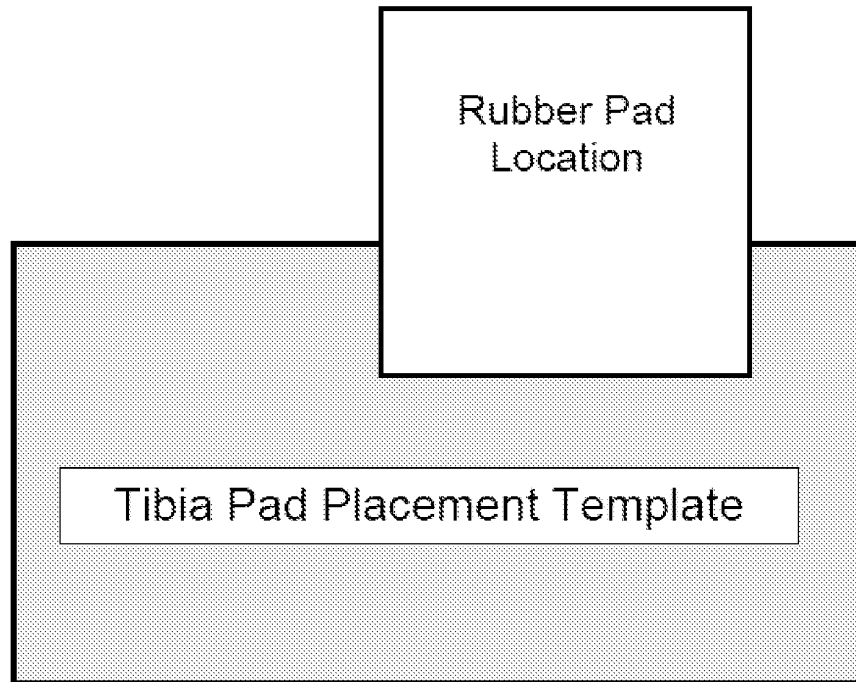

\*Copy and cut out this template.  
Use this template to correctly  
position the tibia pad assembly.

\*The bottom right guide line is  
given as a size reference. This  
line should be 1 inch in size.

